

Airborne Antarctic Ozone Experiment

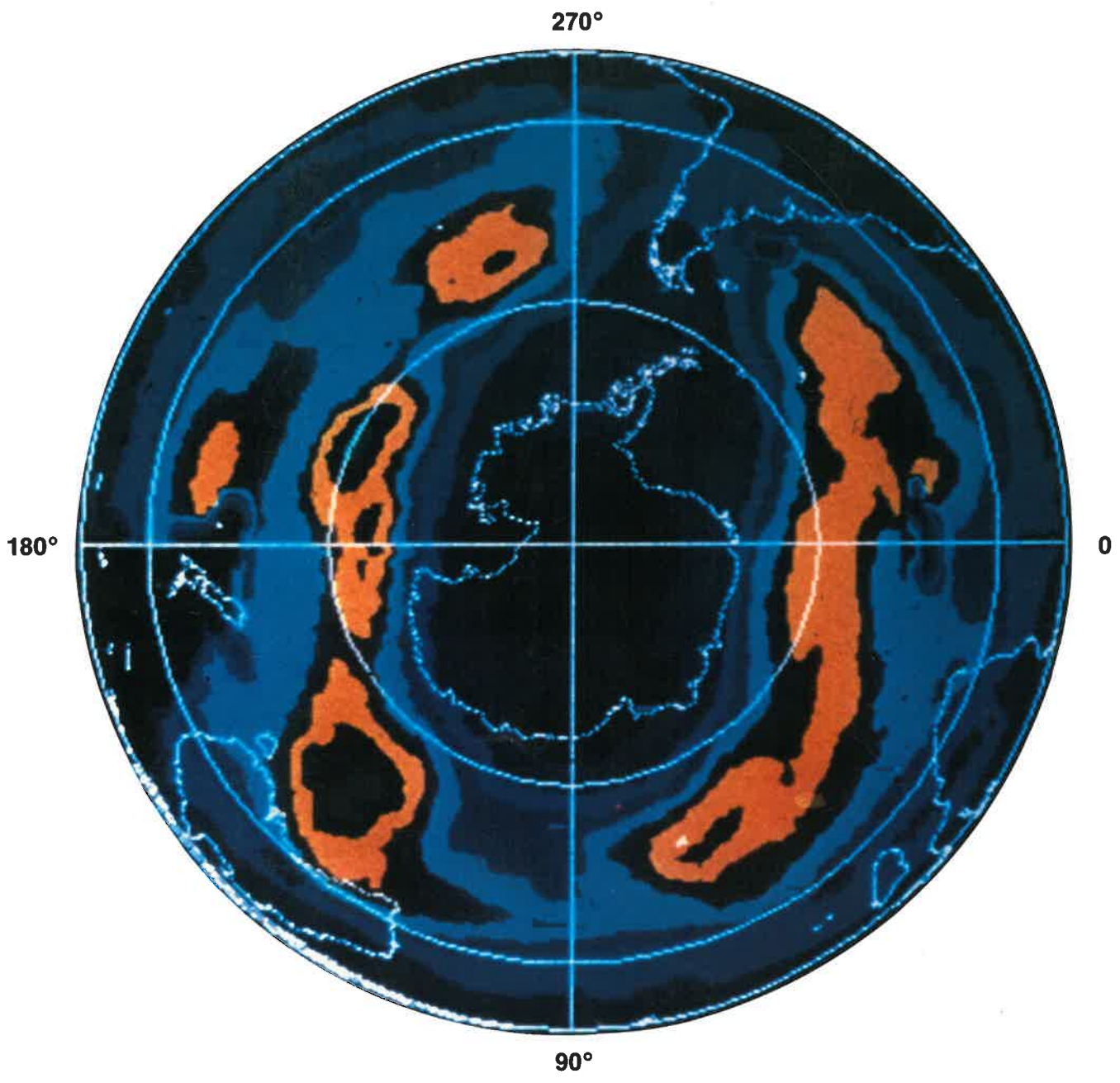

South Polar Plot

NASA
National Aeronautics and
Space Administration
Ames Research Center

NOAA
Aeronomy Laboratory

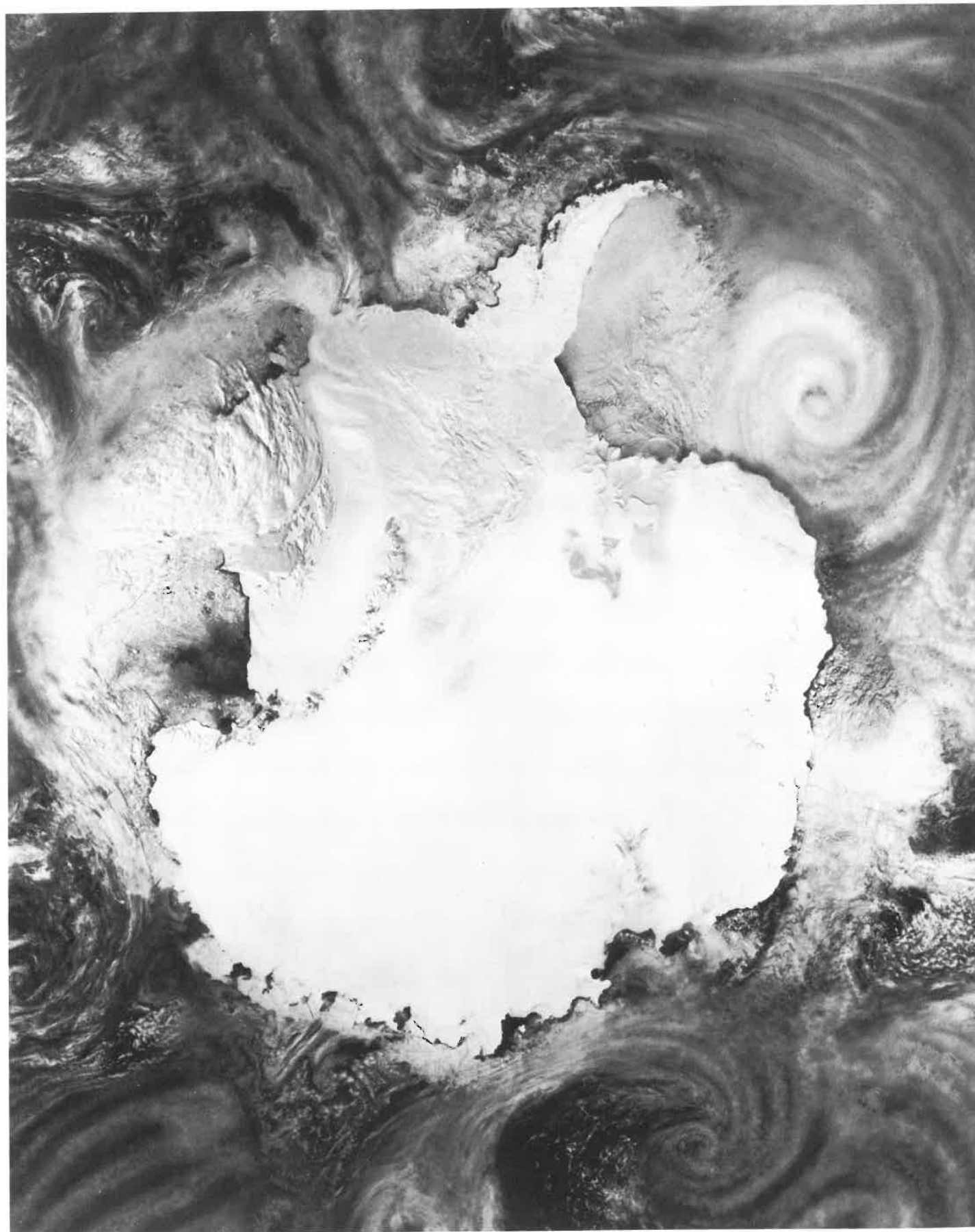

Antarctica, compiled from 5 images, collected between 4 and 25 November 1986.
DMSP Satellite F-7, visible-band, 2.7 km resolution 1986.

Produced from USAF DMSP (Defense Meteorological Satellite Program) film
transparencies archived for NOAA/NESDIS at the University of Colorado,
CIRES/National Snow and Ice Data Center, Campus Box 449, Boulder, CO 80309.

Front Cover:

Courtesy of Arlin Krueger, Principal Investigator for TOMS, Total Ozone
Mapping Spectrometer, on Nimbus 7. Laboratory for Atmospheres,
Goddard Space Flight Center. August 29, 1986

Airborne Antarctic Ozone Experiment

Project Office

MS 245-5

National Aeronautics and Space Administration

Ames Research Center

Moffett Field, California 94035

July 1987

LIST OF CONTENTS

EXECUTIVE SUMMARY

SCIENCE and OBJECTIVES

1

GO/NO-GO CRITERIA

15

KEY PERSONNEL

16

AIRCRAFT PAYLOADS

18

TELECOMMUNICATIONS PLAN

40

DATA PROTOCOL

45

PROJECT ORGANIZATIONAL STRUCTURE

50

APPENDICES

FLIGHT TRACK MAPS

SCHEDULE

MASTER MAILING & PHONE LIST

EXECUTIVE SUMMARY

The Airborne Antarctic Ozone Experiment will fly specially instrumented NASA ER-2 and DC-8 aircraft into the ozone hole in August and September 1987 from the Chilean airfield at Punta Arenas on the Magellan strait, Cape Horn. The experiment will test the current chemical and dynamical theories of the ozone hole using the aircraft data in theoretical computer models of the chemistry and dynamics of the stratosphere. The use of the aircraft data in conjunction with theoretical modelling will provide enhanced scientific insight to optimize flight planning during the mission.

The experimental flying period is from August 17 - September 28; the mission is being organized and mainly funded by NASA, with a substantial contribution from NOAA and with essential involvement by NSF, universities, the Chemical Manufacturer's Association and meteorological agencies overseas.

The two aircraft have largely independent, but complementary scientific payloads. The ER-2 will fly in and directly sample air at those altitudes where the ozone hole is at its most intense, while the DC-8 will fly at the lowermost extremities of the hole and deploy a combination of remote sounding of the overlying atmosphere with some in situ sampling. The payloads may be summarized as follows:

ER-2: Three-dimensional winds, pressure, temperature, temperature profiles \pm 1 km from flight level, ClO, BrO, O₃, NO/NO_y, total H₂O, N₂O, whole air sampling, condensation nuclei, aerosol size distribution and composition, cloud particle images and sizes, all by local methods.

DC-8: O₃ and aerosol profiles overhead by lidar. O₃, BrO, OC10, NO₂, HNO₃, HCl and others, column abundance by remote sensing. O₃, total H₂O and whole air sampling by in situ methods.

The experiment has been designed not only to test existing hypotheses, but also to provide a wide base of high quality data should none of the hypotheses prove to be adequate. Steps have been taken to encourage timely data analysis, with the aim of having the principal investigators meet in February 1988 to discuss their data and interpretations, with publication/ release to the scientific community planned for May 1988.

1987

Introduction

Observations

Recent observations have shown since 1979 a dramatic and unexpected downward trend in the overhead column abundance of ozone during late winter and early spring over Antarctica, at the Halley Bay and Argentine Islands stations (76°S, 27°W and 65°S, 64°W). The reduction, amounting by 1985 to about 40% of the historical October monthly mean, has been confirmed and given a geographically mapped perspective by observations from NASA's Total Ozone Mapping Spectrometer (TOMS) on Nimbus 7. Ozonesonde ascents from Syowa station (69°S, 40°E) in 1982 and 1983 have shown that in October, before the final warming, ozone is depleted by between 10% and 50% at altitudes between about 10 and 22 km, compared to values observed in the late 1960's and early 1970's. The chemical data base has been considerably enhanced by the observations taken from late August to the beginning of November 1986 from McMurdo Base (78°S, 167°E) by the National Ozone Expedition (NOZE), which was organized by NSF. Ozone profiles, 33 in number distributed fairly evenly between 25 August and 6 November, confirmed the picture suggested by the Syowa data, and showed considerable vertical structure in the mixing ratio, particularly during October. It was clear that the ozone loss over McMurdo developed during September. Further, as yet unpublished, observations of the column abundances of O₃, NO₂, and OC10 by the NOAA Aeronomy Lab, of HCl, ClONO₂ and HNO₃ (inter alia) by JPL and observations of N₂O and ClO by SUNY which contain some coarse information about altitude distribution, should all have a substantial impact on knowledge of the photochemical balance, and its interpretation. The NOAA data show evidence of very unusual odd nitrogen chemistry (very low abundance and very small diurnal variation of NO₂ and of unusual chlorine chemistry (high abundance of OC10).

In any instance where spatial or temporal change of a stratospheric chemical species is observed, the first question to be asked is whether it can be attributed to chemical or meteorological processes, or both. Correlations of the Antarctic total ozone amount during the relevant time of year with stratospheric temperature have been reported by five sets of authors in the

special issue of Geophysical Research Letters (November Supplement, 1986). Temperature correlation with ozone does not resolve this issue, since it could be cause or effect. As yet unpublished work from a collaborative study between the UK Meteorological Office, the ECMWF, and the NOAA Aeronomy Lab reveals clear correlations of the area bounded by TOMS total ozone contours in October and the area bounded by the Antarctic sea ice limit in late winter, from 1979-86. In addition, the Halley Bay total ozone amount during October is highly anticorrelated with Southern Hemisphere sea surface temperatures, averaged for July-August-September, over the period 1957-1985, with $r = -0.74$ (significant at better than 1% level). The angular momentum from 1000 to 100 mb, in the latitude belt 51.5°S to 65.9°S has shown a marked increase during the period 1976-1985, a result consistent with an equatorward shift in the contours of zonal mean wind in September, as analyzed by NASA Ames meteorologists from radiosonde data.

Although correlations have been established between tropospheric variables and total ozone during late Antarctic winter, no causal mechanism is immediately evident. The question then arises as to whether there is a corresponding signal of change in any stratospheric dynamical variables. The objectively analyzed cross-section of wind and temperature produced at NASA Ames from radiosonde data show that, for example, the 20 ms^{-1} September zonal mean wind contours enclose a monotonically increasing area; at 50 mb the increase from 1976 to 1980 amounts to a factor of two. Examination of stratospheric potential vorticity fields, calculated with a geostrophic wind assumption from satellite soundings of temperature and pressure, does not show evidence of systematic change in the lower Antarctic stratosphere during late winter. In the upper stratosphere, however, there is evidence of variation in the areas bounded by potential vorticity contours defining the edge of the vortex during much of the winter and spring. During Septembers 1979-86, the area sharply increased by ~20% from 1979 to 1980, and then decreased steadily until by September 1986 it was about 5% below the 1979 value. On the other hand, the October monthly means show an increase in area of about 50% from 1979 to 1985, with a partial recovery in 1986. This could be interpreted as a tendency to a later final warming in October, or as an expanded vortex, or some combination of the two. In either case, the effect would be to produce a downward trend in the total ozone column via the 15-20% of the total column which is above about 30 km. It cannot, however, account for changes of 40-50%

in the total column; most of such large changes can only arise from losses where most of the column is, in the lower stratosphere. Finally, it has been observed that polar stratospheric clouds occur in the same region as the Antarctic ozone depletion, and at about the same time; they have also been observed over small regions and less persistently, during the Arctic winter.

Summarizing the chemical and meteorological data, there is evidence both for an unusual chemical composition in the lower Antarctic stratosphere of late winter, and for changes in the Southern Hemisphere circulation which are correlated with the ozone change.

Theories

There are very broadly two categories of hypothesis which have been advanced to explain the late winter loss of Antarctic ozone. One is that it is essentially chemical in origin, the other that it is caused by a change in the circulation leading to enhanced ingress of ozone-poor air from the troposphere. The chemical theories require some means of maintaining a large positive departure of the mixing ratio of chlorine monoxide from that expected due to standard gas phase stratospheric photochemistry; most hypotheses have appealed to an intervention by heterogeneous phase chemistry occurring on polar stratospheric clouds. One suggestion along these lines is that active chlorine is released from HCl and especially ClONO₂ by reactions on p.s.c., polar stratospheric clouds, surfaces; another is that nitric acid vapor is condensed into p.s.c.'s, having the effect of removing NO_x from the gas phase and so allowing high Cl_x amounts because of the resulting inhibition of ClONO₂ formation. The loss of HNO₃ from the gas phase could permit high HO_x amounts, which in turn can liberate Cl_x from HCl.

There are four chain reactions by which chlorine can destroy ozone:

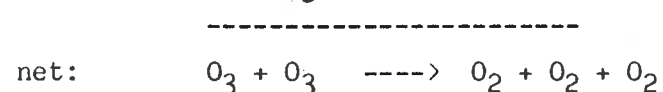
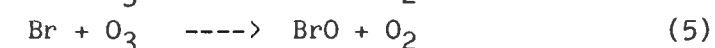
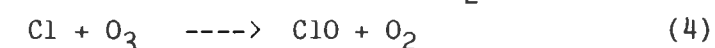
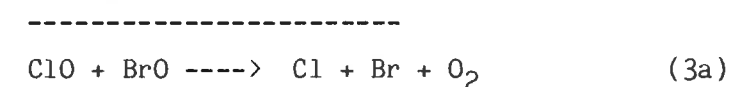
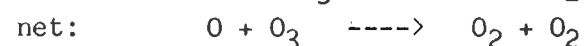
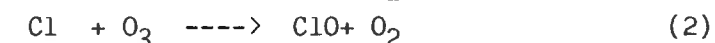
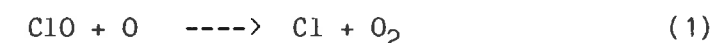

Note that there is another channel in reaction (3)

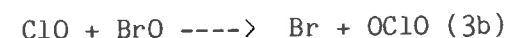

which does not cause catalytic O_3 loss, and which produces the OClO molecule.

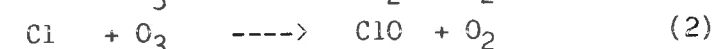
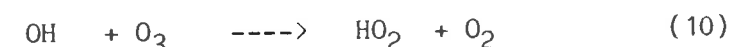
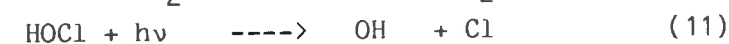
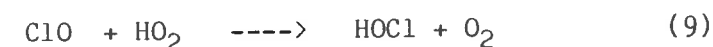
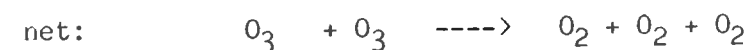
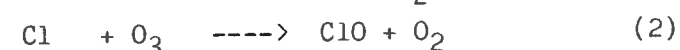
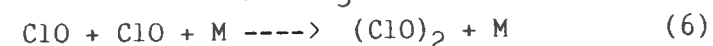

One common feature to all four chain reactions is that ClO is the product of the reaction destroying O_3 , so measurement of it must be a high priority. Measurement of BrO and OClO would decide the extent of occurrence of the 2nd mechanism, (3a-4-5). None of the above mechanisms can be made to work with purely homogeneous gas phase chemistry, because the reaction

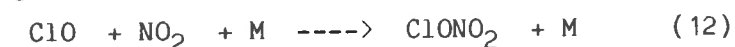

locks up the chlorine in the reservoir species ClONO_2 , which it is thus obviously useful to measure. Another chlorine reservoir is HCl, so this too should be measured. HCl may be in either the gas phase or condensed on particle surfaces.

It is not certain how reactive nitrogen is partitioned between NO, NO_2 , N_2O_5 , HNO_3 and the aqueous phase (in p.s.c.'s), so measurements of these species and/or their sum total in the gas phase is also important. The nitric acid content of p.s.c. particles would provide a crucial constraint.

There are a number of other chemical theories, such as one suggesting a solar cycle induced enhancement of NO_y that would affect ozone. Although these currently seem unlikely, evidence concerning them will be sought.

Measurements of species which have a source at the surface and a sink in the middle and upper stratosphere (for example N_2O , CF_2Cl_2 , CFCl_3) should

provide valuable data on how long the air sampled has been in the stratosphere, and whether it has descended during the period of winter circulation (March - October) from higher levels, or whether it has ascended from the troposphere below. Such measurements, if taken horizontally (or isentropically) across the vortex, could also test another possible mechanism, not so far aired in the literature, that increased frequency in recent years of isentropic transport of air from the lower midlatitude stratosphere to high latitudes would appear as an ozone reduction there; below about 60 mb, the isentropic ozone gradient from 35 S to 90 S appears to be equatorward in late winter.

Operational Plan

Scientific Observations Required to Understand the Antarctic Ozone Hole

There is no doubt that we are data limited. While the data base for the total column content of ozone is excellent, we have a very limited data base for temperature and the vertical distribution of ozone, and a data base limited to total column abundances for some of the many chemical species involved.

To help improve our understanding of the processes which are causing Antarctic ozone to decrease, NASA is planning a two-aircraft experiment in order to obtain a data set that can be used to address the probable causes for the phenomenon.

The aircraft experiment has been designed to test many of the key aspects of the present theories, but has also been designed to provide a rather complete data base of valuable information even if all the current ideas are incorrect.

The NASA ER-2 aircraft and the DC-8 are ideally suited to study this important problem. The ER-2 is the high altitude research aircraft and will be able to penetrate the ozone hole at the altitudes of the maximum decline in ozone. It will carry a suite of in situ experiments that will provide data on the air mass within the confines of the hole itself.

The DC-8 will be equipped with remote sensors that will map the vertical distributions of ozone and aerosols above the cruising altitude of the aircraft and within the hole. There will also be measurements of the column abundance of NO_2 , OClO, BrO, ClONO_2 , HCl, NHO_3 and other species. In addition, the DC-8 will carry a number of in situ experiments because this aircraft will attain altitudes associated with the lower extremes of the ozone hole.

The problem can be summarized as a set of questions and answers:

SCIENCE QUESTIONS

1. Is there sufficient ClO to sustain a fast enough non O-atom chain or chains?
2. What is the extent of Br and BrO involvement?
3. What is the morphology of the ozone depletion?
4. What are the spatial and temporal correlations of O₃ with Cl_x, NO_y, and p.s.c.'s?
5. What is the speciation of NO_y?
6. What is the water vapor mixing ratio?
7. What is the extent, T-dependence, size distribution and chemical composition of particulate matter?
8. How aged (what is the fraction of recent tropospheric origin) is the air in the cold pool beneath the vortex?
9. Is there a coherent pattern to the vertical velocities?
10. If spatial or temporal changes in ozone are detected, can the effects of chemistry and dynamics be separated?
11. To what extent is the assumption of air parcel integrity justified?

MISSION ANSWERS

- | | | |
|---------------------------|--|--------------|
| 1. Anderson (Harvard) | ClO | local ER-2 |
| Wahner (NOAA AL) | OC10 | column DC-8 |
| Farmer (JPL) | ClONO ₂ , HCl, ClO?, HOCl? | column DC-8 |
| Mankin/Coffey (NCAR) | HCl | column DC-8 |
| 2. Anderson (Harvard) | BrO | local ER-2 |
| Wahner (NOAA AL) | BrO | column DC-8 |
| 3. Browell (NASA Langley) | O ₃ | profile DC-8 |
| Farmer (JPL) | O ₃ | column DC-8 |
| Coffey/Mankin (NCAR) | O ₃ | column DC-8 |
| Wahner (NOAA AL) | O ₃ | column DC-8 |
| Gregory (NASA Langley) | O ₃ | local DC-8 |
| 4. Proffitt (NOAA AL) | O ₃ | local ER-2 |
| Starr (NASA Ames) | O ₃ | local ER-2 |
| Anderson (Harvard) | ClO | local ER-2 |
| Fahey (NOAA AL) | NO or NO _y | local ER-2 |
| Wilson (DU) | aerosol | local ER-2 |
| Ferry (NASA/Ames) | aerosol | local ER-2 |
| Browell (NASA Langley) | aerosol | profile DC-8 |
| Farmer (JPL) | O ₃ , several | column DC-8 |
| Mankin/Coffey (NCAR) | O ₃ , several | column DC-8 |
| 5. Farmer (JPL) | NO, NO ₂ , HNO ₃ | column DC-8 |
| Coffey/Mankin (NCAR) | NO, NO ₂ , HNO ₃ | column DC-8 |
| Gandrud (NCAR) | HNO ₃ | local ER-2 |
| Wahner (NOAA AL) | NO ₂ | column DC-8 |
| 6. Kelly (NOAA AL) | H ₂ O vapor (?) | local ER-2 |
| | H ₂ O total | local DC-8 |
| Farmer (JPL) | H ₂ O | column DC-8 |
| Mankin/Coffey (NCAR) | H ₂ O | column DC-8 |

7. Wilson (DU)	0.01-1.0 μm	local ER-2
Ferry (NASA/Ames)	0.1-3.0 μm	local ER-2
	3.0-8.0 μm	
Gandrud (NCAR)	chemical composition	local ER-2
Oberbeck/Pueschel (NASA Ames)	chemical composition	local ER-2
Browell (NASA Langley)	vertical profile $\sim 1\mu\text{m}$	profile DC-8
8. Loewenstein (NASA Ames)	N_2O	local ER-2
Heidt/Vedder (NCAR/Ames)	whole air	local ER-2/DC-8
	CH_4 , N_2O , CO, CFC's	
9. Chan (NASA Ames)	U, V, W, T, p	local ER-2
10. Jones (UK Met O)	Lagrangian photochemistry model	
11. Chan (NASA Ames)	U, V, W, T, p	local ER-2
Gary (JPL)	$\partial T/\partial p$	local ER-2
Heidt/Vedder (NCAR/Ames)	whole air	local ER-2/DC-8

Aircraft observations(A) ER-2 observations:

We propose to operate the ER-2 out of Punta Arenas, Chile (53°S , 71°W). We are planning 10 missions, each with a duration of about 6-8 hours, allowing a range of about 20 degrees of latitude. The field experiment will last approximately 7-8 weeks from the last half of August through the last week of September 1987. This time period should allow us to sample the preconditions during the latter part of August and the most active period of the ozone decline during September. The types of observations to be made and why, the types of instruments to be used, and the names of the principal investigators with their institutions are provided below.

1. Pressure, Temperature, and winds---inertial navigation system---Chan (ARC). This information is needed for navigation as well as for understanding in what air mass the observations are being taken.
2. Ozone (O_3)---ultraviolet absorption---Proffitt (NOAA) and Starr (ARC). Redundant measurements of this key species are vital.
3. Chlorine Monoxide radical (ClO)---conversion to Cl, followed by Cl atom resonance fluorescence---Anderson (Harvard). Redundant measurements of this species will be made because of the central role that it plays in the chemical explanations involving the chlorofluorocarbons. Chemical theories require the concentrations of ClO to be high inside the polar vortex, i.e. close to one ppbv, versus a normal value of less than 0.01 ppbv in the lower stratosphere outside the vortex.
4. Nitric Oxide (NO)---chemiluminescence---Fahey (NOAA). If the current chemical theories based on chlorine are correct then the NO concentrations within the vortex should be extremely low. If solar cycle theories are correct then the NO concentration should be normal or higher.

5. Total Odd Nitrogen (NO_y)---chemiluminescence---Fahey (NOAA). If the solar cycle mechanism is correct then NO_y would be expected to be enhanced within the vortex, whereas normal levels of NO_y would be expected based on the chlorine chemical ideas. Gases such as N_2O_5 and ClONO_2 may react on the surfaces of polar stratospheric clouds leading to a depletion of stratospheric NO_y .

6. Condensation Nuclei (CN)---CN counter---Wilson (Denver). Understanding the formation of polar stratospheric clouds is important if the chlorine based chemical theories are correct.

7. Aerosol Size Distribution---spectrometers---Ferry (ARC) and Knollenberg (PMS Inc.) . . Same justification as #6.

8. Nitrous Oxide (N_2O) or Carbon Monoxide (CO)---tunable infra-red diode laser absorption---Lowenstein (ARC). Nitrous oxide is an excellent tracer of dynamical motions, and thus observations of its vertical distribution will be useful to understand the circulation patterns of the Antarctic region. Measurements of carbon monoxide may provide information on the distribution of the hydroxyl radical.

9. Total water (H_2O)--- Lyman-alpha induced fluorescence--- Kelly (NOAA). Water vapor plays a key role in stratospheric photochemistry. Water may be depleted due to the sedimentation of the polar stratospheric clouds.

10. Temperature lapse rate---microwave emission radiometer---Gary (JPL). This measurement will be used as a measure of the atmospheric stability and for determining potential vorticity which is a conservative dynamical quantity.

11. Bromine monoxide radical (BrO)---chemical conversion followed by Br atom resonance fluorescence---Anderson (Harvard). A measurement of BrO is central to verifying mechanism, which would require the presence of BrO at the level of approximately 10 pptv.

12. Whole air sampler--- CF_2Cl_2 , CFCl_3 , N_2O , CH_4 ---Vedder (ARC) and Heidt (NCAR). These long lived species will serve as tracers of tropospheric air so that we may better understand the dynamical motions associated with the hole.

13. HNO_3 on filters--- HNO_3 ---Gandrud (NCAR)---The abundance of HNO_3 is important to our understanding of the total budget of odd nitrogen, its partitioning between the active and inactive species in the gas phase, and the partitioning between the gas and condensed phase.

14. Particle chemistry and size---wire impactor---Oberbeck (ARC). The relative amounts of sulfate and nitrate ions in stratospheric particles are important in understanding whether the particles are indeed tying up stratospheric NO_y .

The ER-2 payload will consist of the above instrumentation as well as a second inertial navigation system. Redundant measurements for both ozone and ClO were thought to be vital based on scientific and regulatory considerations.

(B) DC-8 Observations:

The DC-8 will be deployed for the same period of time as the ER-2, and while most of the flights will be closely coordinated with those of the ER-2, some flights will be quite independent. The data from the two aircraft will be complementary. Because of the limited range of the ER-2 it will not be able to stay within the vortex for very long, whereas the greater range of the DC-8 will enable it to survey the vortex and explore the region of high ozone outside the vortex. Two round-trip over-the pole flights from Punta Arenas, Chile to Christchurch, New Zealand are planned so that the entire Antarctic region can be mapped and sampled by the on-board instrumentation. The number of flights would be comparable to those of the ER-2; the prime operating site the same as the ER-2: Punta Arenas, Chile.

The payload for the DC-8 consists of the following experiments:

1. Vertical distribution of ozone and aerosols---Lidar---Browell/McCormick (LaRC)
2. Column content of BrO , OClO , NO_2 , O_3 ---Wahner (NOAA)
- 3, 4. Column content of ClO , ClONO_2 , HNO_3 , NO_2 , HCl , HF , etc.---infra-red emission or absorption interferometers---Farmer (JPL), Mankin (NCAR)
5. In-situ ozone---uv absorption---Gregory (LaRC)
6. Total water vapor, in situ---Kelly (NOAA)

7. Whole air sampling---N₂O, CH₄, chlorofluorocarbons, CCl₄, etc.---Heidt (NCAR) & Vedder (ARC)

Meteorologically-guided flight tracks

We will attempt Lagrangian studies of the chemical composition of air parcels by having available isentropic forecasts of the locations of previously sampled air. Simulations of past Septembers suggest that air parcels have a recurrence time over the Palmer Peninsula of 2-8 days, depending upon initial latitude. The Lagrangian approach offers the chance of interpreting the results in a way free of the ambiguities inherent in deconvoluting the effects of chemistry and fluid dynamics in an Eulerian coordinate system; it retains the 3-dimensional, time dependent nature of the stratosphere without the need to resort to global or zonal averages, and can be compared with local observations. A further advantage should also ensue, when the aircraft data are used in a recently published numerical model which integrates a photochemical scheme along isentropic trajectories. Theoretical insight will thus be available during the mission, and should enhance flight planning from the scientific point of view. To achieve the requisite data transfers, it has been necessary to design a large telecommunications network, because the large mainframe computers on which such calculations are made are available only at numerical weather prediction centers, and could not be set up in Punta Arenas.

Weather forecasting - aircraft safety

The surface weather at Punta Arenas can change rapidly when cyclogenesis occurs to the west of the Ross Sea; surface winds of up to 60 knots can occur, and frontal passages are frequent in late winter and spring. In addition temperatures of -95°C or colder may be expected over large volumes of air in the vortex during August and early September, and this may cause problems with aircraft operation. Winds of up to 200 knots may be expected at ER-2 cruise altitudes over the Drake Passage. All these considerations point to having a forecaster experienced in this region, with the best possible forecast charts and products available. This again incurs a considerable telecommunications requirement.

Forecasting the position of the ozone hole

It is of obvious importance to know where the ozone hole is located, if aircraft are to be successfully routed into it. It is planned to have total ozone maps from TOMS available a few hours after they are observed from Nimbus 7, and also to have within 24 - 48 hours data from SBUV and the SAGE II instrument (vertical profiles of O₃, NO₂, H₂O and aerosols). It is hoped to have total ozone retrievals from the HIRS instrument, produced from the 9.6 μm radiances, which would supplement TOMS by showing the total ozone in regions of darkness. A complex telecommunications network is required to provide these capabilities in the remote field site in Punta Arenas.

A block diagram of the mission structure, is shown on the following page.

AIRBORNE ANTARCTIC OZONE DATA NETWORK

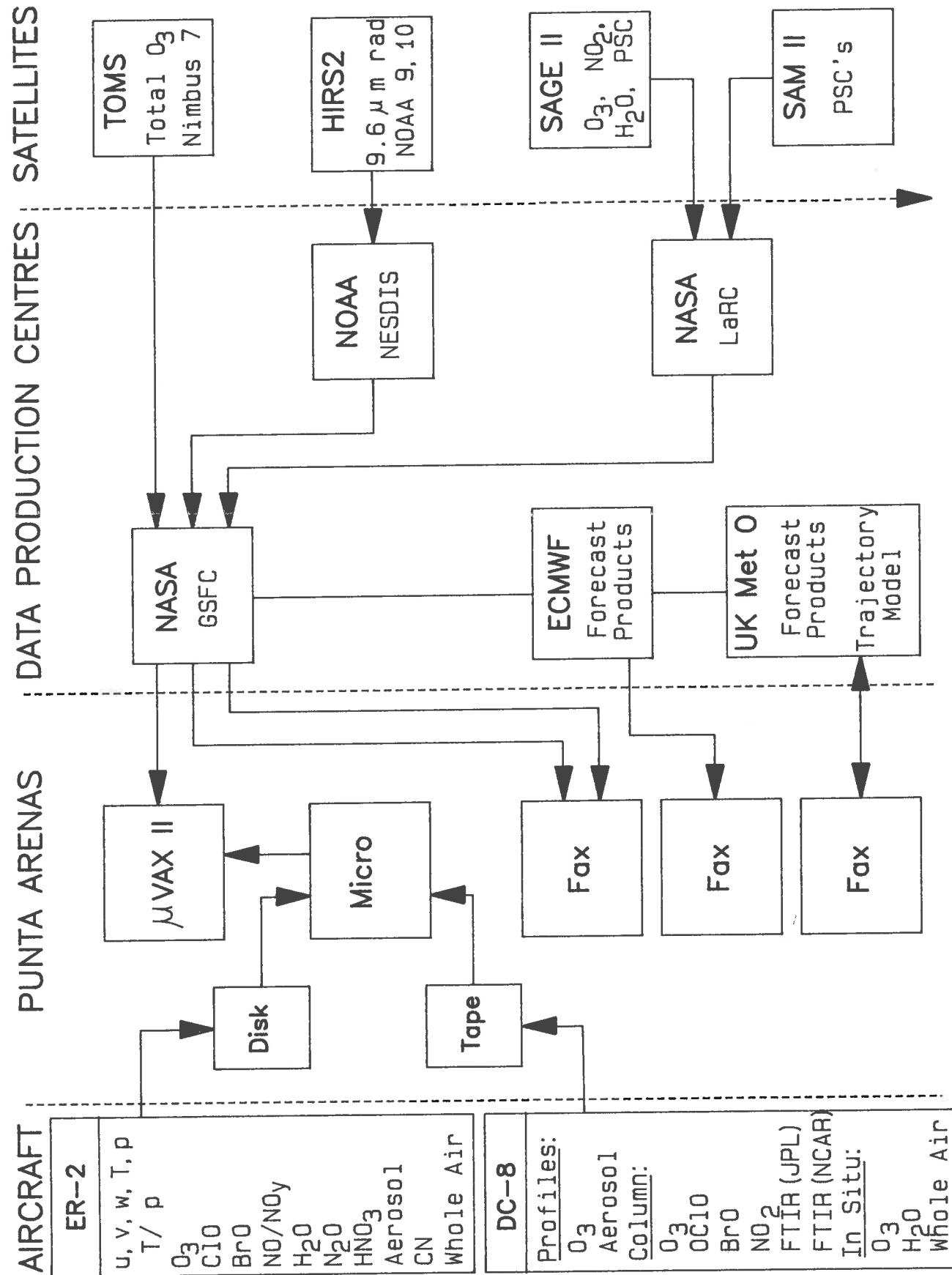

Go/No Go Scientific Functions for Punta Arenas Antarctic Ozone Mission

- 1) Before the ER-2 or DC-8 leave Ames, the following systems must be demonstrated to be operative at Punta Arenas:
 - o TOMS total ozone from GSFC or total ozone via TOVS/DMSF from CNRM, Toulouse
 - o Meteorological forecasting: reception of NWP products at P.A., and ability to make operational prognoses by mission forecaster.

- 2) The following conditions must be met by the payloads of the aircraft before deploying to Punta Arenas:
 - o ER-2: Any two of ClO/BrO, O₃, O₃ and NO_y are a sufficient condition to send the ER-2; if the DC-8 is not available, or if both the JPL-FTIR and NOAA-AL UV spectrometer are inoperable, then the Harvard ClO/BrO is necessary.
 - o DC-8: If any one of the NASA Langley O₃/aerosol lidar, the JPL-FTIR and NOAA-AL UV spectrometer are operable, this is sufficient to send the DC-8; if neither the UV spectrometer or the FTIR is operable, then the Harvard ClO/BrO on the ER-2 is necessary.
 - o In each case, an INS is necessary.

- 3) For individual flights during the mission, the condition in 2) should be used initially, with recognition that they may need to be changed in the light of experience.

A special condition for the period September 8/9 is that the only instrument necessary for a night flight of the DC-8 is the NOAA-AL UV spectrometer.

ANTARCTIC OZONE EXPERIMENT
KEY PERSONNEL
JUNE 1987

Program Management

Robert T. Watson, Program Scientist, NASA Headquarters
James Margitan, Program Manager, NASA Headquarters

Project Office

Estelle P. Condon, Project Manager, NASA Ames
Guy Ferry, Deputy Project Manager & Science Coordinator, NASA Ames
Adrian Tuck, Project Scientist, NOAA AL
Brian Toon, Deputy Project Scientist, NASA Ames
Alvin J. Wilhelmi, Instrument Manager, NASA Ames
Arthur Mandell, Project Control Officer, NASA Ames
Peter Salter, Forecaster, UK Met O

Operations Management

Science & Applications Aircraft Division
Jim W. Cherbonneaux, Chief

High Altitude Missions, NASA Ames

John C. Arvesen, Branch Chief
Jim L. Barrilleaux, Assistant Branch Chief
Earl Petersen, Integration Manager, DC-8

Medium Altitude Missions, NASA Ames

Don L. Anderson, Branch Chief
George Grant, Assistant Branch Chief

Lockheed

John Reller, Aircraft Manager, DC-8
Ron R. Williams, Chief of Operations
Jack L. Wall, Chief of Maintenance
William H. Ferguson, Engineer

Northrop Service Inc.

Mr. Ed Mitz, Resident Manager

ER-2 Principal Investigators

Jim Anderson, Harvard Univ.	Ken Kelly, NOAA AL
K. Roland Chan, NASA Ames	Max Loewenstein, NASA Ames
David Fahey, NOAA AL	Verne Oberbeck, NASA Ames
Guy Ferry, NASA Ames	Michael Proffitt, NOAA AL/CIRES
Bruce Gandrud, NCAR	Walter Starr, NASA Ames
Bruce Cary, JPL	Jim Vedder, NASA Ames
Leroy Heidt, NCAR	J. Charles Wilson, U. of Denver

DC-8 Principal Investigators

Ed Browell, NASA Langley	Ken Kelly, NOAA AL
C. Barney Farmer, JPL	William Mankin, NCAR
Gerry Gregory, NASA Langley	Jim Vedder, NASA Ames
Leroy Heidt, NCAR	Andreas Wahner, NOAA AL

ANTARCTIC OZONE EXPERIMENT
KEY PERSONNEL
JUNE 1987

Satellite Principal Investigators

D. Cariolle, CNRM
A. Krueger, NASA Goddard
P. McCormick, NASA Langley

Theory Team

D. Hartmann, U. of Wash.
R. Jones, UK Met O
J. Rodriguez, AER, Inc.
M. Schoeberl, NASA Goddard
N. Sze, AER, Inc.

OZONE/AEROSOL LIDAR
BROWELL/McCORMICK-NASA Langley

F.T. INTERFEROMETER
FARMER-JPL

F.T. SPECTROMETER
MANKIN-NCAR

UV/BLUE SPECTROGRAPH
WAHNER-NOAA

WHOLE AIR SAMPLER
VEDDER-NASA Ames
HEIDT-NCAR

OZONE CHEMILUM. DET.
GREGORY-NASA Langley

LYMAN ALPHA HYGROMETER
KELLY-NOAA

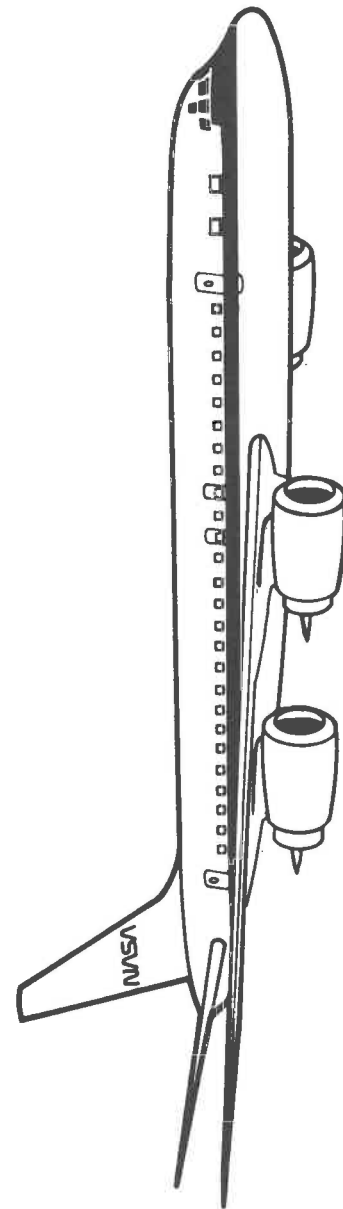

Instrument: OZONE AND AEROSOL DIAL SYSTEM

Principal Investigator: Edward V. Browell

Organization: NASA Langley Research Center
Mail Stop 401A
Hampton, VA 23665-5225

(804) 865-2576
FTS 928-2576

Principle of Operation:

The airborne differential absorption lidar (DIAL) system consists of four lasers that transmit simultaneously four laser wavelengths (300, 314, 600, and 1064 nm) through the zenith-mounted quartz window of the DC-8. The DIAL technique for the measurement of O_3 profiles uses the 300 and 314 nm laser outputs as the "on-" and "off-line" wavelengths, respectively. The laser wavelengths at 600 and 1064 nm are used to profile the distribution of aerosols and clouds at the same time as the O_3 profile is being measured. Backscatter returns from the atmosphere at the four laser wavelengths are collected by a zenith viewing telescope, directed on to separate detectors, digitized, recorded, and analyzed in real time. Simultaneous color plots of aerosol/cloud distributions and O_3 distributions are produced on the DC-8 for real-time experiment sampling decisions. The system is operated at a 10 Hz rate with the average lidar data stored at 1 Hz (15 m vertical resolution; 200 m horizontal resolution). The vertical and horizontal resolutions for the aerosol/cloud analysis are 100 m and 2 km, respectively, over the range 1-11 km above the aircraft. The O_3 concentration profiles have a vertical and horizontal resolution of 300 m and 20 km, respectively, over the range 1-8 km above the aircraft.

Accuracy: $\leq 10\%$ for O_3 concentrations; $\leq 5\%$ for aerosol backscatter returns

Resolution:

	Aerosols	O_3
Vertical	100 m	300 m
Horizontal	2 km	20 km

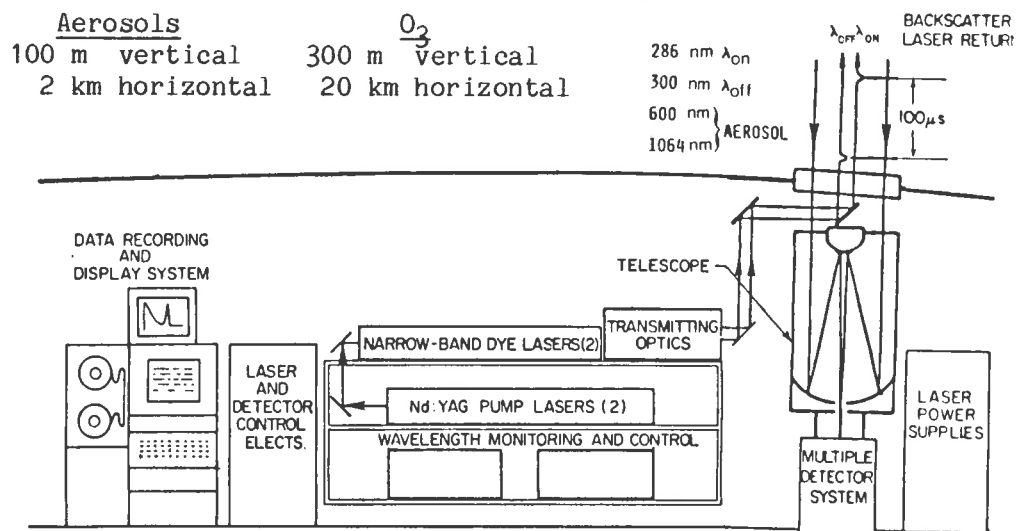

References:

1. E. V. Browell et al., NASA Multipurpose Airborne DIAL System and Measurements of Ozone and Aerosol Profiles, Appl. Opt., 22, 522-534, 1983.
2. E. V. Browell, E. F. Danielsen et al., Tropopause Fold Structure Determined from Airborne Lidar and In Situ Measurements, J. Geophys. Res., 92, 2112-2120, 1987.

Instrument: MARK IV INTERFEROMETER

Principal Investigator: Crofton B. Farmer

Organization: Jet Propulsion Laboratory (818) 354-2039
4800 Oak Grove Drive FTS 792-2039
Pasadena, CA 91109

Principle of Operation:

The Mark IV interferometer is capable of detecting most of the major and minor atmospheric constituents which have molecular transitions in the 2 to 16 micrometer region of the near infrared spectrum. These include O_3 , HNO_3 , NO , NO_2 , HCl , HF , $ClONO_2$, several CFCs (CCl_2F , CCl_3F), H_2O , CH_4 , CO_2 , which are of particular interest to present ozone depletion studies. The instrument is a Michelson Fourier spectrometer which observes the sun while recording an interferogram every 100 seconds as the optical path difference changes by 66 cm. Each interferogram is converted to a high resolution (0.012 cm^{-1}) spectrum from which compositional information is obtained. The optical path difference is varied by moving a retroreflector along a lead screw driven by a constant velocity DC motor through a belt drive. The interferogram is recorded on two channels covering two different parts of the wavelength interval. The data are stored on Winchester disks for Fourier transformation and analysis after completion of each observation period, which is on the order of 20 minutes. The data storage system and Fourier transform system are part of the instrument control unit. A separate ground station is used for detailed data analysis and data archiving after each flight.

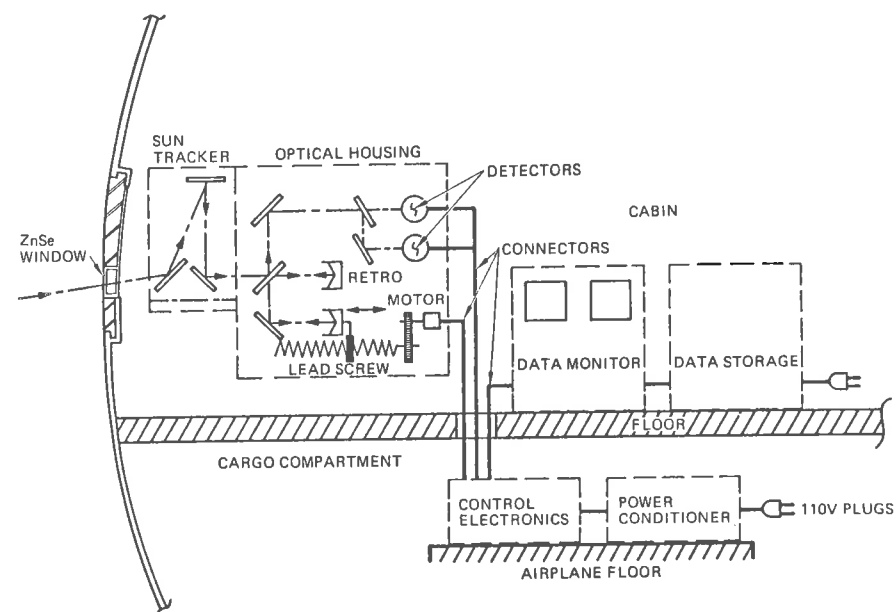

Accuracy: Depends on molecular constituents; 3 to 10% typically.

Constituents to be Observed: O_3 , HNO_3 , NO , NO_2 , HCl , HF , $ClONO_2$, H_2 , N_2O , CH_4 , CO_2 and several CFCs. (Upper limits to be obtained for $HOCl$, ClO , ClO_2 if levels too low for detection).

Response Time: 100 seconds

Location in DC8: Cabin (forward section, left side) and cargo compartment.

Instrument: CHEMILUMINESCENT OZONE DETECTOR

Principal Investigator: Dr. Gerald L. Gregory

Organization: NASA/Langley Research Center (804) 865-4341
Mail Stop 483 FTS 928-4341
Hampton, VA 23665-5225

Principle of Operation:

The concentration of O_3 is determined by measuring the light produced from the chemiluminescent reaction of ethylene (C_2H_4) and the O_3 in the sample. The light output is detected by a photomultiplier tube and the resulting signal conditioned to a 0-1 V instrument output. The chemiluminescent reaction occurs on a molecular basis (one molecule O_3 -one molecule C_2H_4) with a surplus of C_2H_4 being supplied to the reaction chamber. Instrument detection limit is of the order of 2 ppb with a 90 percent response of about 3 sec.

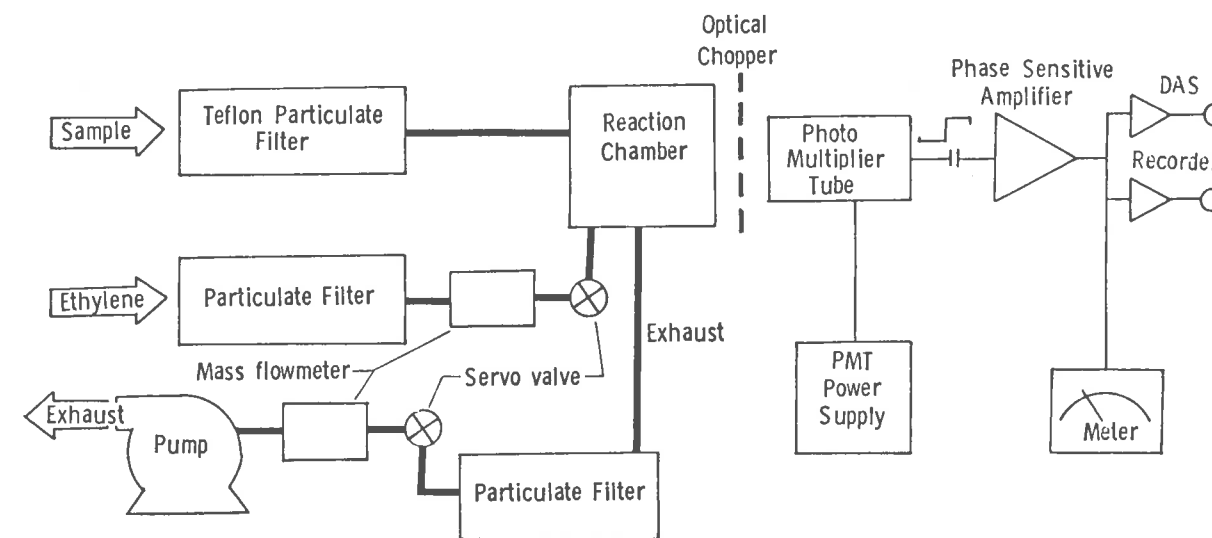

Accuracy: 5% or ± 5 ppbv

Precision: 2% or ± 2 ppbv

Response Time: 3 Seconds

Reference: G. L. Gregory, C. H. Hudgins, and R. E. Edahl, Laboratory Evaluation of an Airborne Ozone Instrument That Compensates for Altitude/Sensitivity Effects, *Environ. Sci. Technol.*, 17, 100-103, 1983.

Instrument: WHOLE AIR SAMPLER

Principal Investigators: Leroy E. Heidt and James F. Vedder

Organizations:

National Center for Atmospheric Research 1850 Table Mesa Drive Boulder, CO 80307 (303) 497-1459	NASA Ames Research Center Moffett Field, CA 94035 (415) 694-6259 FTS 464-6259
--	--

Principle of Operation:

The primary purpose is the measurement of several long-lived gases at interval along the flight path for identification of parcels of air and their motions and origins. The selected gases include the first nine species listed below.

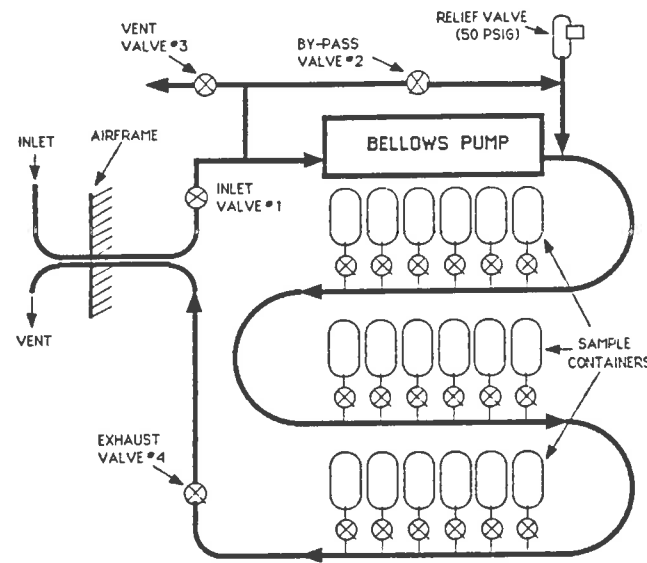

Table 1. Proposed Trace Gas Measurements from Whole-Air Sampling
f=mixing ratio by volume

Species	Lifetime (Yr)	f	15-20 Km Est. f	Measurement Accuracy (%)	Results Available (Days)
PPMV					
CO ₂	5	345	340-335	3.0	1
PPBV					
CH ₄	10	1600	1500-1450	3.0	1
N ₂ O	150	303	280-180	2.0	1
CO	0.4	50	40-10	2.0	1
PPTV					
CFC 11	75	240	120-30	0.5	1
CFC 12	110	390	300-150	1.0	1
CFC 113	150	45	15-15	1.0	1
CH ₃ CCl ₃	9	150	10-2	0.5	1
CCl ₄	50	160	70-10	1.5	1
CH ₃ Br	3	10	?	1.0	30
CH Br ₃	0.1	2	?	0.3	30
CH ₃ Cl	1.5	600	200-80	10.0	30
C ₂ H ₆	0.17	500	200-20	10.0	30
C ₂ H ₂	0.06	50	15-5	10.0	30

Instrument: LYMAN α HYGROMETER

Principal Investigator: Ken Kelly

Organization: NOAA/ERL/Aeronomy Laboratory 325 Broadway, R/E/AL6 Boulder, CO 80303	(303) 497-3345 FTS 320-3345
--	--------------------------------

Principle of Operation:

A 121.6 nm light source dissociates a fraction of the water and forms excited hydroxyl radicals. These radicals will either fluoresce at 309 nm or be quenched by air molecules. A PMT measures the 309 nm light, which is proportional to the water vapor mixing ratio. A photodiode monitors the 121.6 nm intensity at the same distance as the sample chamber center. An inflight calibration is obtained from the measured absorption of 121.6 nm light by injected water vapor, the known absorption cross section and the chamber pressure. The hygrometer will measure total water.

Detection System:

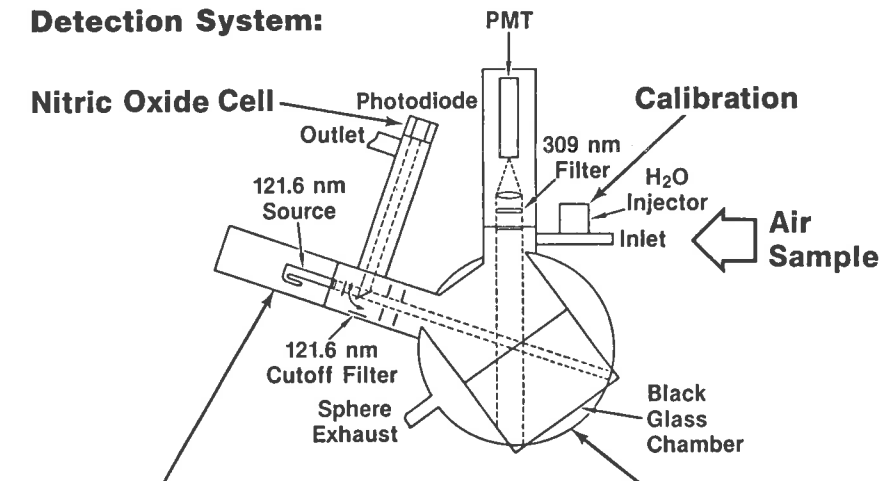

- Lamp:**
- DC Discharge
 - Ceramic body
 - UH₃ source

- Fluorescence Cell:**
- Black glass cube
 - Retroreflecting corners
 - Externally pumped

Accuracy: 6%

Detection Limit: .1 ppmv

Response Time: 1 sec.

Location on DC-8: Station 308-316

Reference: Kley, D., A. Schmeltekopf, K. Kelly, R. Winkler, T. Thompson, M. McFarland, The U-2 Lyman-alpha results from the 1980 Panama Experiment, In: The 1980 Stratospheric-Tropospheric Exchange Experiment, ed. A. P. Margozzi, NASA Tech. Memo 84297, 85-125, 1983.

Instrument: FOURIER TRANSFORM SPECTROMETER

Principal Investigators: W. G. Mankin, M. T. Coffey

Organization: National Center for Atmospheric Research
P. O. Box 3000 (303) 497-1403 (Mankin)
Boulder, Colorado 80307 (303) 497-1407 (Coffey)

Principle of Operation:

The instrument consists of a Fourier transform spectrometer with apodized resolution of 0.06 cm^{-1} which observes the infrared radiation from the sun. Atmospheric molecular species above the aircraft absorb the radiation at characteristic wavelengths. The instrument observes wavelengths from 2 to $15 \mu\text{m}$ where almost all molecules absorb. Measurements are made of the total column above the aircraft of O_3 , H_2O , CO_2 , CH_4 , N_2O , NO , NO_2 , HNO_3 , HCl , HF , CO , OCS , C_2H_6 , F-11, F-12, and HCN . It is anticipated that real time column amounts will be available for some species.

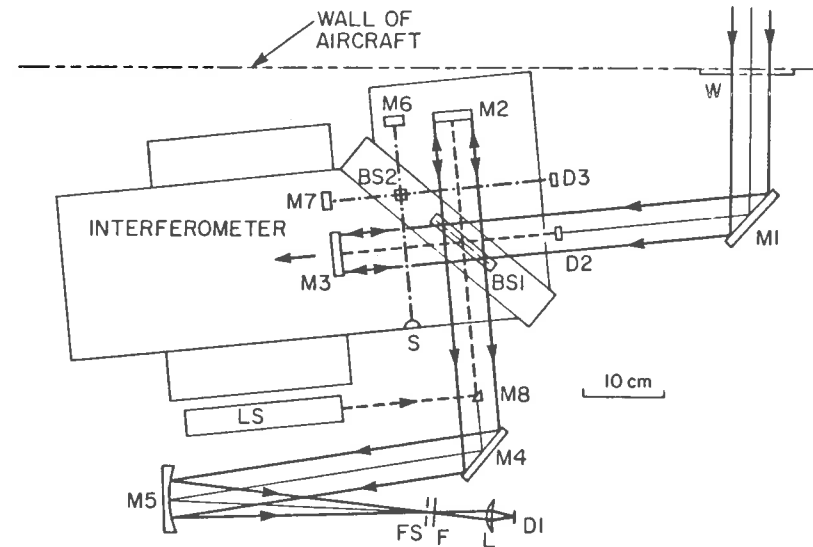

Accuracy: 10% - 25% depending upon species.

Precision: Varies with species, typically 10%.

Time: 6-12 sec. per spectrum.

Location on DC8: Left side, forward.

Reference: William G. Mankin, Airborne Fourier Transform Spectroscopy of the Upper Atmosphere, Optical Engineering 17, 39-43 (1978).

Instrument: NOAA NEAR UV ATMOSPHERIC ABSORPTION EXPERIMENT

Principal Investigators: A. Wahner and R. Jakoubek

Organization: NOAA Aeronomy Lab (303) 497-5826
325 Broadway (303) 497-5797
Boulder, CO 80303

Scientific Objectives/Method: - Measurement of OC10 , BrO , O_3 , and NO_2 column abundances made by near ultraviolet/blue atmospheric absorption of these molecules in scattered solar skylight, direct sunlight, and direct moonlight

Instrumentation: -

- crossed Czerny-Turner double spectrograph
- FOV: 0.6 degree x 0.06 degree
- spectral coverage: 348 nm-388 nm; survey from atm cutoff to red
- spectral resolution: 0.4 nm; spectral bandpass: 40 nm
- detector
 - 1×1024 element cooled reticon array - $0.025 \times 2.5 \text{ mm}^2$ pixels
 - 10 pixels illuminated per spectral full width-half maximum
- integration times for detector saturation:
 - day (scattered sunlight): 8 sec; night (moon): 120 sec
- weight: 600 pounds - power: 110 VAC, 60 hz, 5 KW

Daytime Detectability Limits: (APPROXIMATE)

- OC10 : $5 \times 10^{12} \text{ cm}^{-2}$ column abundance
- BrO : $5 \times 10^{12} \text{ cm}^{-2}$ column abundance
- NO_2 : $7 \times 10^{13} \text{ cm}^{-2}$ column abundance
- O_3 : $3 \times 10^{16} \text{ cm}^{-2}$ column abundance

Flight and Aircraft Requirements:

- aircraft attitude
 - roll: +/-20 deg (day) +/-20 deg @ <0.25 deg/sec(night)
 - pitch: +/-20 deg (day) +/-20 deg @ <0.25 deg/sec(night)
 - yaw: X +/-20 deg @ <0.25 deg/sec(night)
- aircraft altitude: experiment will work at all altitudes during the day; $h > 10 \text{ km}$ at night for moonflights
- flight track/flight timing
 - day: as for other instruments; data will be taken any time the sun is greater than 95 deg zenith angle. We want as much data as possible near 90 SZA. We will occasionally need to look directly at the sun
 - night: maximum time extension of moonrise using aircraft velocity to west starting at lunar zenith angle 90 deg. in hole
- INS: require aircraft position and altitude in real time so we can analyze our data during the flight
- aircraft window for both vertical and horizontal viewing: quartz

Date Analysis:

- real time on aircraft for preliminary science decisions
- secondary analysis on ground; first order turn around in one day

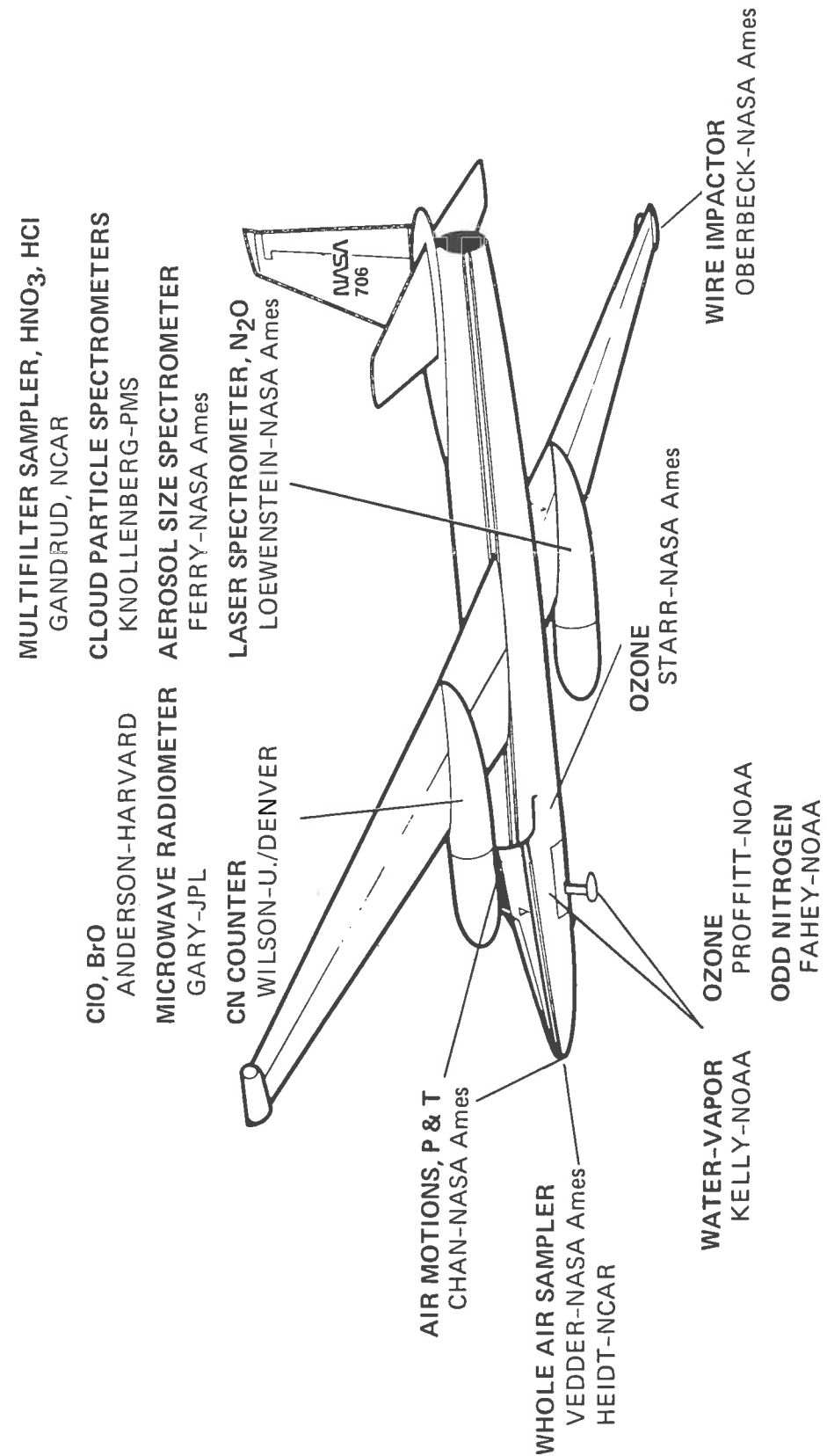

ER-2 Instrument Configuration for Antarctic Ozone

Instrument: MULTIPLE AXIS RESONANCE FLUORESCENCE CHEMICAL CONVERSION DETECTOR FOR ClO AND BrO

Principal Investigator: James G. Anderson

Organization: Department of Chemistry and (617) 495-5922
 Department of Earth and Planetary Science
 Harvard University
 40 Oxford Street, Cambridge, MA 02138

Principle of Operation:

Vacuum ultraviolet radiation produced in a low pressure plasma discharge lamp is used to induce resonance scattering in Cl and Br atoms within a flowing sample. ClO and BrO are converted to Cl and Br by the addition of NO such that the rapid bimolecular reaction $ClO + NO \rightarrow Cl + NO_2$ ($BrO + NO \rightarrow Br + NO_2$) yields one halogen atom for each halogen oxide radical present in the flowing sample. Three detection axes are used to diagnose the spatial (and thus temporal) dependence of the ClO (BrO) to Cl (Br) conversion and to detect any removal of Cl (Br) following its formation. A double duct system is used both to maintain laminar flow through the detection region and to step the flow velocity in the detection region down from free stream (200 m/sec) to 20 m/sec in order to optimize the kinetic diagnosis.

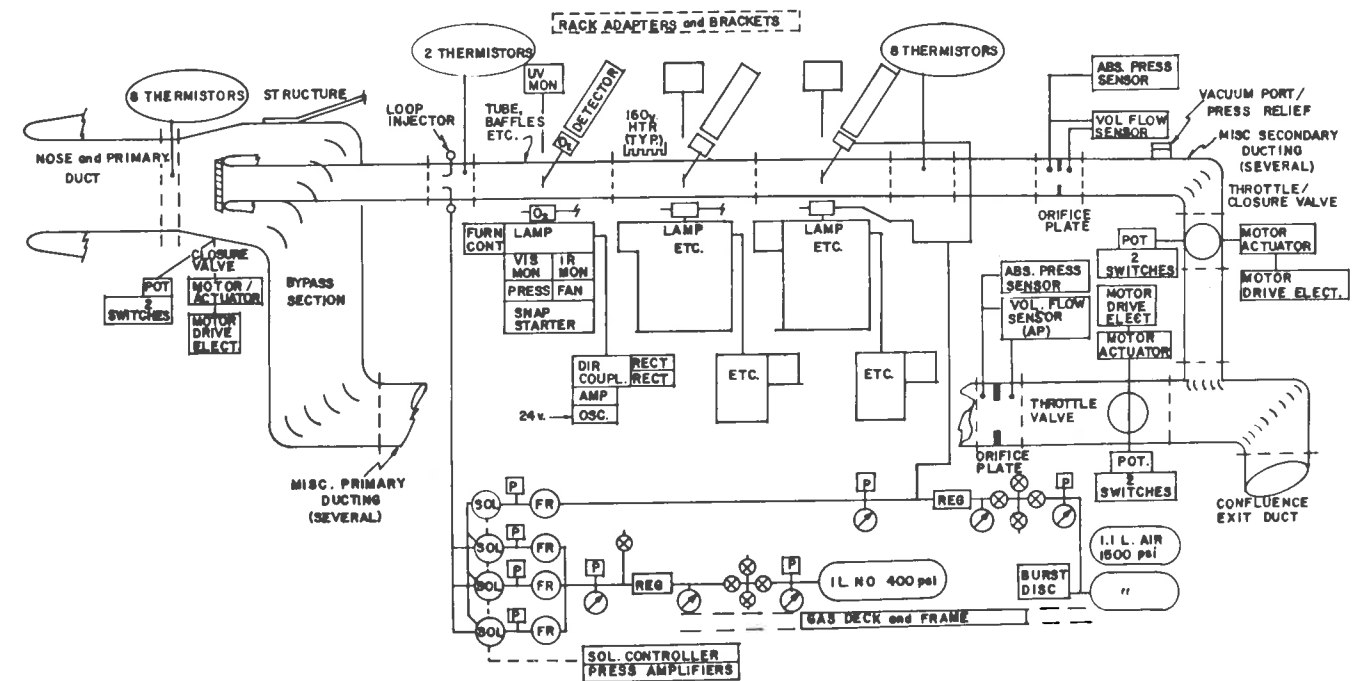

Accuracy: ± 15 percent

Precision: ± 5 percent

Response Time: Depends on ClO concentration. At 10 ppt 10 seconds, at 0.5 ppb < 1 sec

Reference: Brune, W.H., and J.G. Anderson, Geophys. Res. Lett. 13, 1391, 1986.

Instrument: ER-2 METEOROLOGICAL MEASUREMENT SYSTEM (MMS)

Principal Investigator: K. Roland Chan

Organization: NASA, Ames Research Center (415) 694-6263
 M.S. 245-5 FTS 464-6263
 Moffett Field, CA 94035

Instrument Description: The ER-2 Meteorological Measurement System (MMS) consists of (1) pressure/temperature/airflow angle sensor subsystem, (2) inertial navigation subsystem, and (3) data acquisition subsystem. The MMS performance specifications, system block diagram, and instrument location are shown below.

Pressure: ± 0.25 mb
 Temperature: ± 0.25 C
 Wind vector: ± 1 m/sec
 Sampling rate: 5 Hz

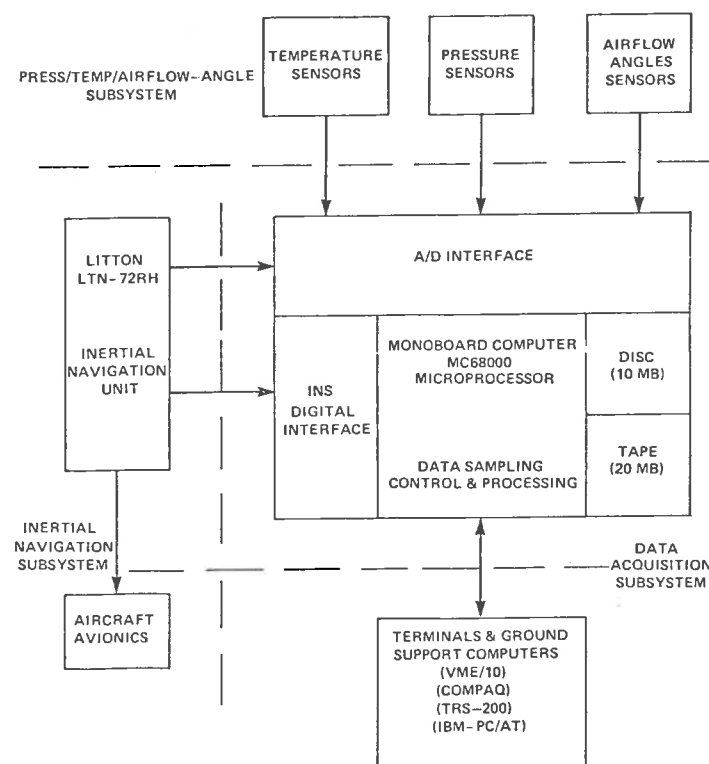
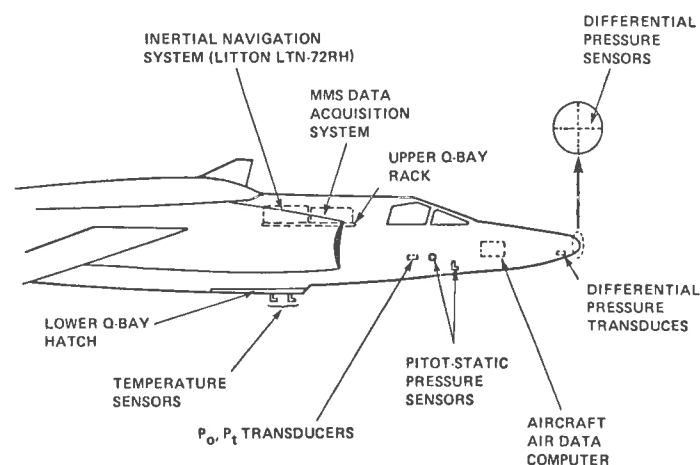

Instrument: NO_y DETECTOR

Principal Investigator: David W. Fahey

Organization: NOAA Aeronomy Laboratory (303) 497-5277
 325 Broadway, R/E/AL6 FTS 320-5277
 Boulder, CO 80303

Principle of Operation:

The instrument is designed to measure NO_y, the sum of reactive nitrogen oxide species, in a sample flow of ambient air. NO_y includes NO, NO₂, NO₃, HNO₃, N₂O₅ and PAN. The technique utilizes the catalytic reduction of the higher oxides to NO on a 300°C gold surface in the presence of added CO. The total NO is then measured with a chemiluminescence detector that measures the NO₂ emission produced in the reaction of NO with added O₃. O₃ reagent is produced in situ in a silent O₂ discharge. A constant mass flow is maintained through the catalytic converter and detector with a mechanical vacuum pump. The converter and sample flow valve are located external to the aircraft in a pod designed to provide sampling points that discriminate against particles and hydrometeors $\geq 5\mu\text{m}$ in diameter.

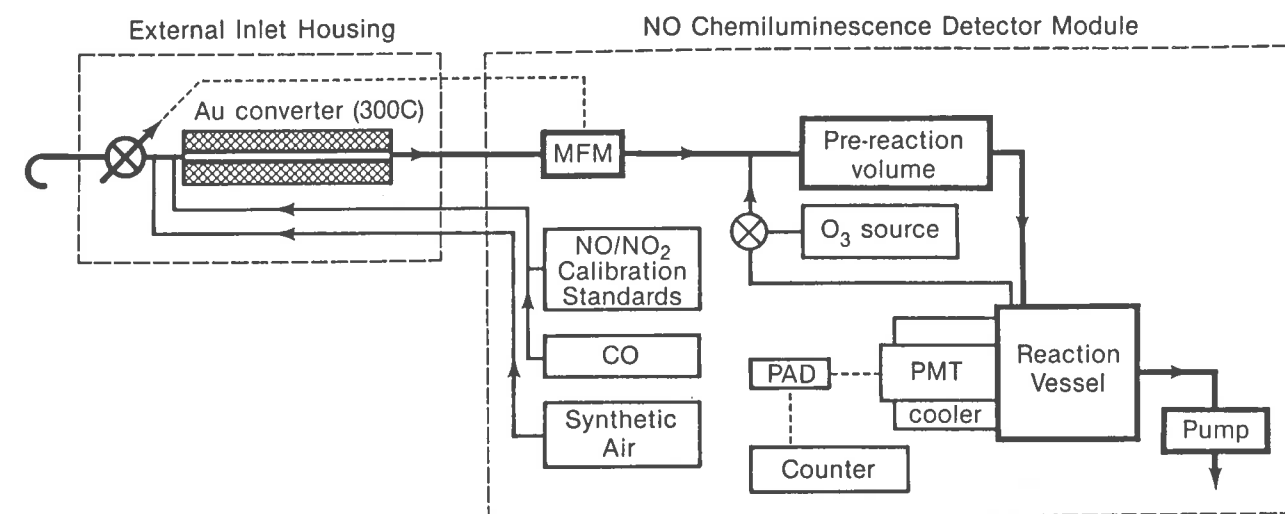

Accuracy: $\pm 20\%$ plus precision

Detection Limit: < 50 pptv

Response Time: 1 sec

Location on ER-2: Lower Q-bay rack

Reference: D. W. Fahey, C. S. Eubank, G. Hubler, and F. C. Fehsenfeld, Evaluation of a catalytic reduction technique for the measurement of total reactive odd-nitrogen NO_y in the atmosphere, *J. Atmos. Chem.*, **3**, 435-468 (1985).

Instrument: AEROSOL AND CLOUD SPECTROMETERS

Aerosol Principal Investigator: Guy V. Ferry

Organization: NASA-Ames Research Center (415) 694-5492
M. S. 245-5 FTS 464-5492
Moffett Field, CA 94035

Principle of Operation:

The aerosol spectrometers size aerosol particles by measuring the amount of laser light scattered by the aerosol particles as they pass through a laser beam. The instrument system is composed of three parts: (1). a small particle size aerosol spectrometer (PMS model ASAS-X probe), (2). a medium particle size aerosol spectrometer (PMS model FSSP-100), and (3). a data acquisition and recording system. The small particle size aerosol spectrometer and the data acquisition and recording system are combined in one package. The medium particle size aerosol spectrometer is in a separate package.

The small particle size aerosol spectrometer measures particles in the 0.1 to 3.0 micrometer size range. It is an active cavity spectrometer. It draws sample air in through an inlet into the laser cavity. The sample air is dynamically focused into the laser beam by filtered sheath air. The measured particles are divided into 31 size intervals and an oversize bin.

The medium particle size aerosol spectrometer is a forward scattering spectrometer probe. Particles are sized by measuring the amount of light scattered into the collecting optics during particle interaction through a focused laser beam. This instrument measures particles in the 0.5 to 8.0 micrometer size range. The measured particles are divided into 15 size intervals.

Sampling Rate: 0.1 hertz

Location on ER-2: ASAS-X and Data system - rear of right pod
FSSP - nose of right pod

Instrument: MULTI FILTER SAMPLER (MFS)

Principal Investigator: Bruce W. Gandrud

Organization: National Center for Atmospheric Research (303) 497-1425
1850 Table Mesa Drive
Boulder, Colorado 80307

Principle of Operation:

The MFS is designed to measure aerosols and gases in the stratosphere by collection on a filter medium. The MFS cycles filters in and out of the airstream and isolates the sampled as well as the unsampled filters from contamination. The sampler is operated by the pilot, with automatic sequencing of a filter into position from a single switch position change in the cockpit. The air flow is measured with a propeller anemometer. The air temperature, pressure, flow and instrument diagnostics are recorded with an on board data acquisition system.

After a flight, the filters are extracted with an aqueous solution containing a wetting agent. This aqueous solution is analyzed by Ion Chromatography to determine the amounts of each ion collected.

Accuracy: +/- 20%

Detection Limit: This is directly dependent on the length of time that the filter is exposed to the airstream. Given a 15 minute exposure, the detection limits for sulfate and nitrate ion are about 0.5 ppbm.

Location on ER-2: Right Wing tank

References:

- B. W. Gandrud and A. L. Lazrus, Measurements of Stratospheric Sulfate Mixing Ratio with a Multi Filter Sampler, GRL, 8(1), 1981, p. 21-22.
- B. W. Gandrud and A. L. Lazrus, Filter Measurements of Stratospheric Sulfate and Chloride in the Eruption Plume of Mount St. Helens, Science, 211, 1981, p. 826-827.
- B. W. Gandrud, M. A. Kritz and A. L. Lazrus, Balloon and Aircraft Measurements of Stratospheric Sulfate Mixing Ratio Following the El Chichon Eruption, GRL, 10(11), 1983, p. 1037-1040.

Instrument: MICROWAVE TEMPERATURE PROFILER

Principal Investigator: Bruce L. Gary

Organization: Jet Propulsion Laboratory (818) 354-3198
 M/S T1182-3 FTS 792-3198
 4800 Oak Grove Drive
 Pasadena, CA 91109

Principle of Operation:

A passive microwave radiometer measures thermal emission from oxygen molecules for a selection of elevation angles. The observing frequencies are 57.3 and 58.8 GHz. The relationship between "brightness temperature" and elevation angle can be converted to a plot of "air temperature versus altitude" using simple algorithms. Lapse rate at A/C altitude can later be compared with horizontal gradients of wind speed to derive "potential vorticity." Potential vorticity is a property of an air mass that is "conservative," as it does not change during a stratospheric/ tropospheric exchange process (provided there is no mixing with ambient air during or after the exchange process). Potential vorticity determinations will be used to assign an origin to the air mass being flown through.

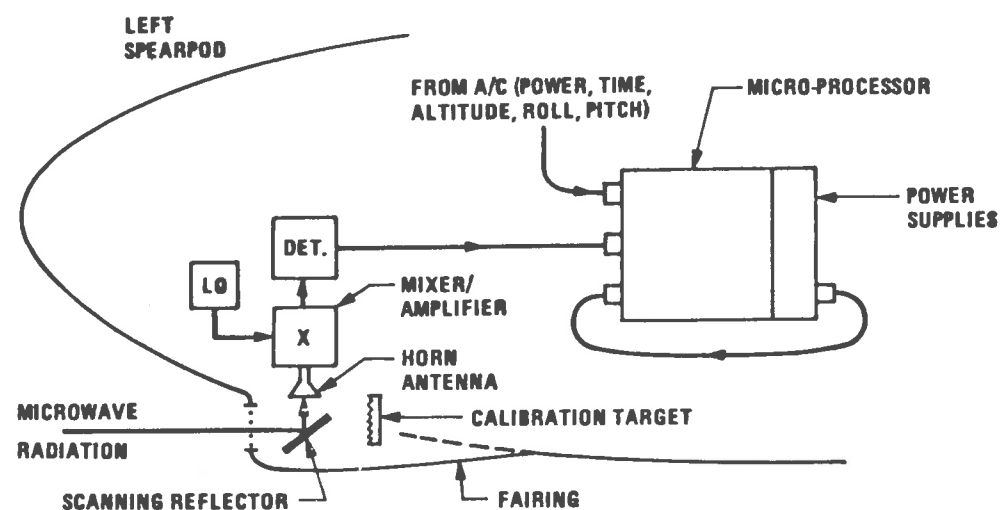

Precision: Temperature lapse across 2000 foot layer (at A/C altitude) is accurate to 0.25 degK, every 14 seconds (which corresponds to lapse rate of 0.45 degK/km). Better accuracies are obtained across thicker layers.

Accuracy: Approximately 10% of the measured lapse rate.

Response Time: Altitude temperature profiles are obtained once every 14 seconds. The profile applies to a volume of air that is approximately 3 km deep (along flight path) by 3km high (centered on A/C) and 1/4 km wide. Lapse rate oscillations of wavelength 4 km (period = 20 sec) will be "smeared" to 50% amplitude. These spec's are for altitude of 50 kft.

Location of ER-2: Left Spearpod; fairing on outboard side.

Instrument: WHOLE AIR SAMPLER

Principal Investigators: Leroy E. Heidt and James F. Vedder

Organizations:

National Center for Atmospheric Research NASA Ames Research Center
 1850 Table Mesa Drive Moffett Field, CA 94035
 Boulder, CO 80307 (415) 694-6259
 (303) 497-1459 FTS 464-6259

Principle of Operation:

The primary purpose is the measurement of several long-lived trace gases at intervals along the flight path for identification of parcels of air and their motions and origins. The selected gases include the first nine species listed below.

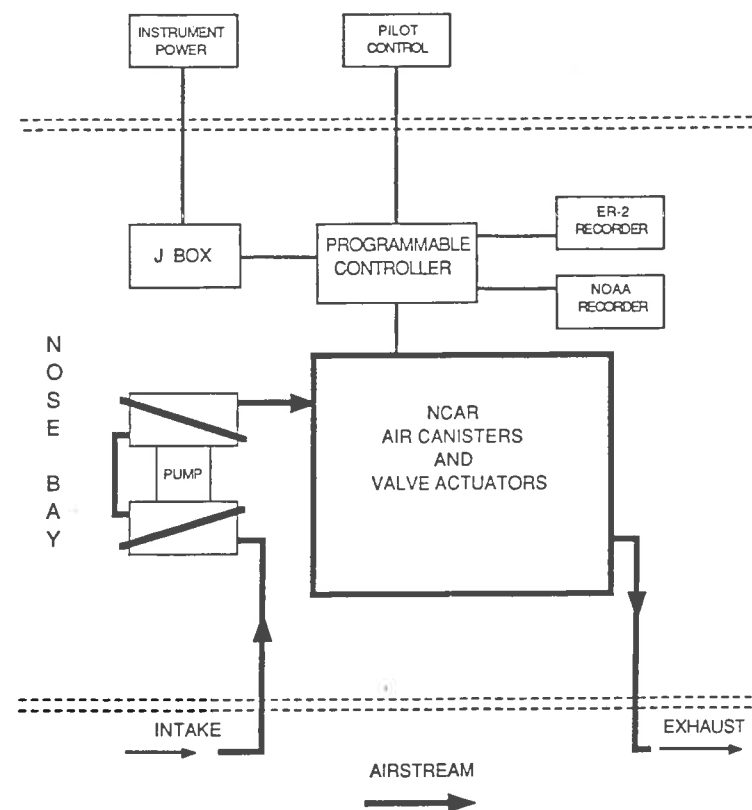

Table 1. Proposed Trace Gas Measurements from Whole-Air Sampling
 f=mixing ratio by volume

Species	Lifetime (Yr)	f	15-20 Km Est. f	Measurement Accuracy (%)	Results Available (Days)
PPMV					
CO ₂	5	345	340-335	3.0	1
PPBV					
CH ₄	10	1600	1500-1450	3.0	1
N ₂ O	150	303	280-180	2.0	1
CO	0.4	50	40-10	2.0	1
PPTV					
CFC 11	75	240	120-30	0.5	1
CFC 12	110	390	300-150	1.0	1
CFC 113	150	45	15-15	1.0	1
CH ₃ CCl ₃	9	150	10-2	0.5	1
CCl ₄	50	160	70-10	1.5	1
CH ₃ Br	3	10	?	1.0	30
CH Br ₃	0.1	2	?	0.3	30
CH ₃ Cl	1.5	600	200-80	10.0	30
C ₂ H ₆	0.17	500	200-20	10.0	30
C ₂ H ₂	0.06	50	15-5	10.0	30

Location on ER-2: Nose Bay

Instrument: LYMAN α HYGROMETER

Principal Investigator: Ken Kelly

Organization: NOAA/ERL/Aeronomy Laboratory
325 Broadway, R/E/AL6
Boulder, CO 80303

(303) 497-3345
FTS 320-3345

Principle of Operation:

A 121.6 nm light source dissociates a fraction of the water and forms excited hydroxyl radicals. These radicals will either fluoresce at 309 nm or be quenched by air molecules. A PMT measures the 309 nm light, which is proportional to the water vapor mixing ratio. A photodiode monitors the 121.6 nm intensity at the same distance as the sample chamber center. An inflight calibration is obtained from the measured absorption of 121.6 nm light by injected water vapor, the known absorption cross section and the chamber pressure. One hygrometer will measure total water; the other will measure water vapor with the particles inertially separated.

Detection System:

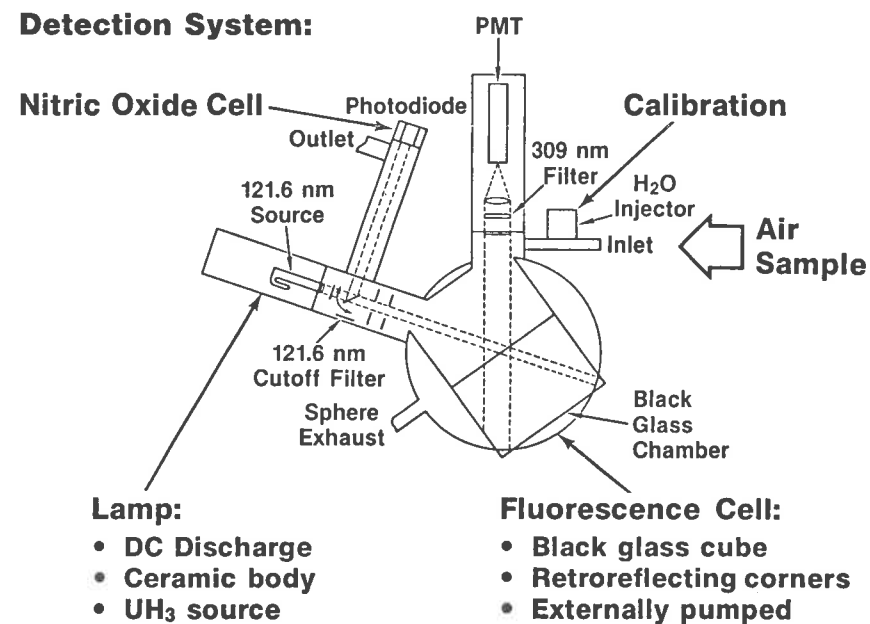

Accuracy: 6%

Detection Limit: .1 ppmv

Response Time: 1 sec

Location on ER2: Q-Bay

Reference: Kley, D., A. Schmeltekopf, K. Kelly, R. Winkler, T. Thompson, and M. McFarland, The U-2 Lyman-alpha results from the 1980 Panama Experiment, In: The 1980 Stratospheric-Tropospheric Exchange Experiment, ed. A. P. Margozi, NASA Tech. Memo 84297, 85-125, 1983.

Instrument: ATLAS: AIRBORNE TUNABLE LASER ABSORPTION SPECTROMETER

Principal Investigator: Max Loewenstein

Associate Principal Investigator: James Podolske

Organization: NASA Ames Research Center
Atmospheric Experiments Branch
Mail Stop 245-5
Moffett Field, CA 94035

(415) 694-5504
FTS 464-5504

Principle of Operation:

The instrument detects an infrared active target gas (e.g. CO or N₂O) by measuring the fractional absorption of the infrared beam from a tunable diode laser as it traverses a multipass White cell containing an atmospheric sample at ambient pressure. The laser source is tuned to an individual rotational-vibrational line in an infrared absorption band of the target gas, and is frequency modulated at 2kHz. Synchronous detection of the resultant amplitude modulation at 2kHz and 4kHz yields the first and second harmonics of the generally weak absorption feature with high sensitivity ($\Delta I/I < 1E-5$). Part of the main beam is split off through a short cell containing a known amount of the target gas to a reference detector. The reference first harmonic signal is used to lock the laser frequency to the absorption line center, while the second harmonic signal is used to derive the calibration factor needed to convert the measurement beam second harmonic amplitude into absolute gas concentration. A zero beam is included to suppress laser excess noise and unwanted baseline structure. The response time of the instrument is set by the gas flow rate through the White cell, which is normally set to give a new sample every second. Periodic standard additions of the target gas are injected into the sample stream as a second method to calibrate the measurement technique.

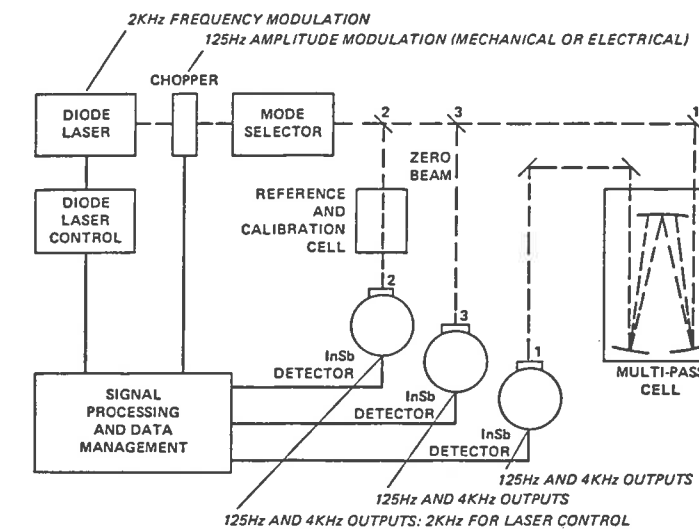

Accuracy: 5% \pm 1ppbv (for CO)

Resolution: 1ppbv

Response Time: 1 second

Location on ER-2: Spear Pod, right wing

Instrument: PARTICLE CHEMISTRY IMPACTOR EXPERIMENT

Principal Investigator: Verne R. Oberbeck

Organization: NASA Ames Research Center
Moffett Field California 94035

(415) 694-5496
FTS 464-5496

Principle of Operation:

The instrument consists of 500 micron gold wires deployed in the air stream on ring mounts. Some are coated with salts which are selected to produce unique morphologic characteristics when reacted with the acids or with gases injected at the sample altitude. Additional tests for chemistry are based upon morphologic changes resulting from controlling the relative humidity. Six samples per flight can be exposed for up to 10 minutes each to document spatial change in nitrates, sulfates and other species. Size distributions of sulfates will be obtained and subtracted from total size distributions available from other experiments. This will give chemical information as a function of size for other species.

Accuracy: $\pm 15\%$ on particle radius

Sample Time: 2-10 minutes

Location on ER-2: Wing tip

Reference: Verne R. Oberbeck, E.F. Danielsen, K.G. Snetsinger, G.V. Ferry, W. Fong, and D.M. Hayes, "Effect of the Eruption of El Chichon on Stratospheric Aerosol Size and Composition, Geophysical Research Letters," Vol. 10, No. 11, pp. 1021-1024; 1983.

Instrument: DUAL-BEAM UV-ABSORPTION OZONE PHOTOMETER

Principal Investigator: Michael H. Proffitt

Organization: NOAA/ERL/Aeronomy Laboratory
325 Broadway MS R/E/AL6
Boulder, CO 80303

(303) 497-3345
FTS 320-3345

and
Cooperative Institute for Research in Environmental Sciences
University of Colorado

Principle of Operation:

The instrument consists of a mercury lamp, two sample chambers that can be periodically scrubbed of ozone, and two detectors that measure the 254 NM radiation transmitted through the chamber. The ozone absorption cross-section at this wavelength is accurately known, hence, the ozone number density can be easily calculated. Since the two absorption chambers are identical, virtually continuous measurements of ozone are made by alternating the air sample and the scrubbed sample between the two chambers. At a one second data rate, the minimum detectable concentration of ozone (one standard deviation) is 1.5×10^{10} mo1/cm³ (0.6 ppbv at STP).

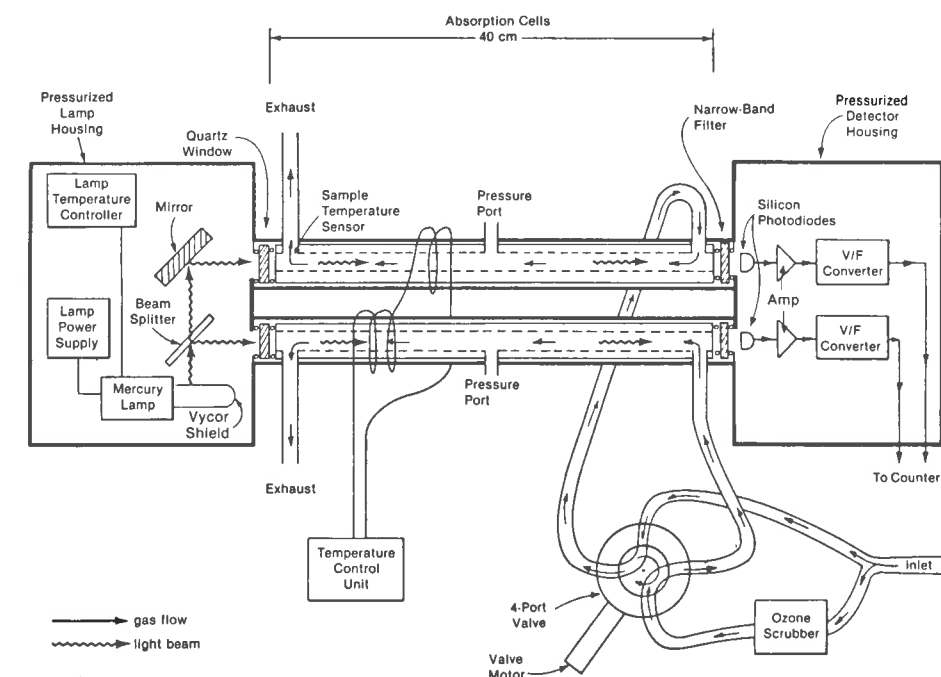

Accuracy: 3% + precision

Precision: 1.5×10^{10} mo1/cm³ of ozone

Response Time: 1 Second

Location on ER2: Q-Bay

Reference: Michael H. Proffitt and Richard J. McLaughlin, Fast-Response Dual-Beam UV-Absorption Ozone Photometer Suitable for Use on Stratospheric Balloons, Rev. Sci. Instrum., Vol. 54, 1719-1728 (1983).

Instrument: AMES ULTRAVIOLET OZONE PHOTOMETER: UOP/ER-2

Principal Investigator: Walter L. Starr

Organization: NASA Ames Research Center (415) 694-5503
Moffett Field, CA 94035 FTS 464-5503

Principle of Operation:

This instrument determines the amount of ozone in sampled air by measuring the transmission of UV radiation through a known pathlength of air with and without ozone present. The pressure and temperature of the sampled air, which flows continuously through the instrument, are also measured. Ultraviolet radiation of 253.7 nm generated by a mercury lamp is utilized. This radiation lies almost exactly at the wavelength of maximum near-UV absorption by ozone. By suitable choice of filters and radiation detectors, essentially all the measured radiation is from this single mercury line for which an accurate value of the absorption coefficient is known. These measurements together with the absorption coefficient yield the atmospheric ozone mixing ratio.

In operation the instrument is cycled between a measure and a null mode. In the null mode the airflow is diverted through a catalytic converter which removes ozone from the air sample before it enters an absorption cell. In the measure mode the sampled air passes directly into the cell. Two photodiode radiation detectors are used: one measures the radiation intensity transmitted through the cell during both the measure and null modes, and the second monitors the lamp intensity. This monitor detector signal permits the inclusion of the effects of lamp intensity variations in the calculation of ozone amount. Measure and null mode durations can be set to any desired values.

The outside free-stream total air temperature, pressure, and Mach number are also measured during flight. From these measurements and the measured mixing ratio, ozone concentrations in the ambient air may also be determined as a function of aircraft altitude or ambient air temperature. Air temperature versus altitude or time can also be determined from these measurements.

A microprocessor controls the programmed operation of the instrument. Measurements are made at a 1-Hz rate and the data is stored in battery-backed RAM for read out on the ground by a portable computer. The instrument is located in the aft section of the ER-2 equipment bay.

Instrument: CONDENSATION NUCLEUS COUNTER (CNC)

Principal Investigator: James C. Wilson (303) 871-3002
University of Denver
Department of Engineering
2390 S. York St.
Denver, Co 80208

Instrument Description: The condensation nucleus counter was developed for use on NASA high altitude aircraft and measures the number concentration of aerosol particles having diameters in the 0.01 to about 1.0 micron range. The instrument operates at altitudes from 8 km to 21.5 km. Recent developments include an impactor which can be used to remove particles larger than 0.11 micron in diameter. This permits a direct measurement of the population of particles smaller than the detection limit of the PMS ASAS-X which is often flown at the same time as the CNC.

Instrument Function: The instrument functions by saturating the aerosol sample with warm alcohol vapor and then cooling the sample so that the alcohol vapor condenses on particles in the sample causing them to grow to the sizes which can easily be detected by a simple optical particle counter. Thus individual particles are counted.

Data Quality: Laboratory studies have been made of the response of the instrument as a function of particle size and pressure. The precision of the instrument has been checked in laboratory studies and was found to be within a few percent of that implied by counting statistics. The sampling inlet used with the CNC was instrumented and the inlet performance in flight was studied to insure that submicron particles are sampled representatively. Housekeeping data are recorded on each flight to ensure that the temperatures of the saturator and condenser are within the normal operating ranges. Thus for aerosols whose number distribution is dominated by particles larger than 0.02 microns in diameter, the submicron number concentration is probably measured with an uncertainty of less than 20% and a precision smaller than 10%.

Utilization: The CNC has been used in the Aerosol Climatic Effects Study and in the Stratosphere-Troposphere Exchange Study. It has flown over 50 times and has operated on NASA U-2 and ER-2 aircraft.

Reference: Wilson, James Charles, Edmund D. Blackshear and Jong Ho Hyun, "The Function and Response of an Improved Stratospheric Condensation Nucleus Counter," Journal of Geophysical Research: Oceans and Atmosphere 88: 6781-6785, (1983).

RDS Ozone Hole Network

The following is a description of the RDS Ozone Hole Network to support NASA's Ozone Hole Experiment. Attached is a copy of the RDS network design.

Overview

The network is designed to support voice communications with the Goddard Space Flight Center (GSFC) CBX 9000 to allow dial out capability both locally and using FTS. Additionally, the network will support facsimile operations and 9.6 kbps data transmissions utilizing DECNET software for transmission of X.25 data from the VAX 11/750. Raw radiance data from NOAA/NESDIS may have to be put on tape and then on a GSFC VAX for transmission to the European Centre for Medium-Range Weather Forecasting (ECMWF). The network is configured with one PABX at the ECMWF and one at the British Meteorological Office (BMO). The communications lines are designed so that the personnel in Punta Arenas, Chile, may communicate to GSFC via telephone lines that appear to be off-premises extension (OPX) lines. The same is true for the lines that connect ECMWF and BMO. They will appear as off-premises extensions at the PBX's, thereby presenting in Punta Arenas four (4) lines at the airfield in the Terminal Building, Room 1 (the NASA-RDS Communications Center). There will be other lines in the Communications Center which will be explained later. The CBX 9000 in GSFC will be connected to the PABX at ECMWF through a patch panel used to provide a 4-wire path for data end-to-end.

Redundancy is provided by designing the communication architecture in the form of loops. Therefore, should a connection be broken between GSFC and Punta Arenas, the information can be routed via the U.K. If a connection goes down between GSFC and the U.K., the connection can be made via Punta Arenas. A breakdown between the U.K. and Punta Arenas can be rerouted via GSFC.

ECMWF Berkshire

The ECMWF circuit to GSFC will enter the ECMWF communications facility and be connected to a patch board. The circuit between GSFC and ECMWF is a 4-wire, M1020 circuit which extends through the patch board to a coherent kit for signaling and exits the coherent kit on a 2-wire circuit to enter the PABX on the line side. The PABX will show the same configuration from the extension side to Punta Arenas thereby reacting as an off-premises extension in Punta Arenas.

Additionally, the PABX will receive, on the line side, one access line with a number assignment to the Reading telephone exchange. The PABX will have two (2) extensions connected to facsimile machines with telephone instruments attached. There will be one extension with a direct connection to a telephone instrument. This telephone will be manned 24-hours per day. The operator will be called when it is desired to send data between ECMWF and other locations. Upon request, the operator will patch through data to the Cray, BMO or other location thus ensuring a 4-wire connection end-to-end (except for extremely short tails). This will ensure the maintenance of highest quality communication paths for data.

On the user side of the patch board the 4-wire line will pass through a hybrid to convert the 4-wire to a 2-wire connection for entry to a RM-9632 modem. The modem will be connected via a V.24/V28 connection to the designated computer receiving the raw radiance data from the GSFC VAX. This machine will provide the interface with the Cray computer.

BMO Bracknell

The BMO will bring through its entrance facilities a 4-wire connection to the ECMWF and a 4-wire connection to Punta Arenas. Both 4-wire circuits will terminate on a single patch board. The line from Punta Arenas will be extended through the patch board to a coherent kit. From the coherent kit user's side a 2-wire circuit will enter the extension side of the PABX provided by British Telecommunications International (BTI). The circuit will enter as an extension port. The PABX will have an extension connected to a facsimile machine, supplied by BTI, with telephone instrument. An additional extension position on the PABX will be a direct connection to a telephone instrument. This instrument will be manned 24 hours per day. The operator will perform the same functions as described under ECMWF Berkshire. On the user's side of the patch panel the 4-wire circuit will be converted to 2-wire for a Racal-Milgo 9632 modem to provide for data transmission (requires manual patch for data).

NOTE: All international lines will be M1020 lines for alternative voice and data (AVD).

RDS-NASA Communication Center

Punta Arenas

At Punta Arenas Airport Terminal Building, Room 1, RDS will establish a telecommunications center. Entel-Chile will bring all circuits received from U.S. and Britain to a 24-circuit main distribution frame (MDF) to be placed on the wall in Room 1. Entel-Chile will then terminate on that MDF two (2) circuits from GSFC and two (2) circuits from Britain, one each from ECMWF and BMO. Additionally, Entel-Chile will provide three (3) Central Office telephone lines to that MDF with numbers assigned from the Chilean Telephone Company (CTC) for use as DDI telephones connected to rooms at the hotel in Punta Arenas. One of the lines will be for facsimile and voice. Entel-Chile will also provide telephone instruments. FACH will provide 2 additional telephone lines from hanger #1 at the Chibunco Air Base to be terminated on the MDF.

RDS will provide a patch panel capability for connecting different instruments and equipment to different line positions. RDS will, with the assistance of Entel-Chile, connect the patch panel with the line side connected to the four (4) M1020 circuits. On the line side, RDS, with Entel-Chile's assistance, will connect coherent kits, provided by RDS, to three Nefax facsimile machines (to GSFC, BMO, ECMWF) with telephone instruments and a Racal-Milgo 9632 modem (to GSFC) to be connected to a micro-VAX/II computer. Additionally, a Nefax with phone instrument will be connected directly to the MDF for connection to a Central Office DDI line. From the MDF two (2) telephone instruments will be connected to two additional access lines to the Central Office (DDI). Further, the two (2) lines from Hanger 1 shall be equipped with instruments and signaling necessary to communicate with personnel in Hanger 1. These

instruments will be connected so that when the handset goes off-hook the corresponding phone at the other location immediately begins to ring.

Cape Horn Hotel in Punta Arenas

Entel-Chile will issue orders to the Chilean Telephone Company to install 3 telephone lines with direct connection between the Central Office and rooms designated by the hotel manager. The hotel PBX will be bypassed. These lines will be DDI lines. One line will have a Nefax and handset attached and the others, phone instruments only.

GSFC

GSFC has a Rolm CBX 9000 switch. GSFC has main entrance facilities in Building 1 where a MDF resides. All circuits connected internationally will enter GSFC for connection at the main entrance facilities and reside on the MDF. GSFC's Rolm switch personnel will order lines to be connected from the MDF to the CBX 9000. These lines shall be connected on the line side of the switch but be configured to appear as off-premises extensions. GSFC will provide the necessary analog/circuit facilities. GSFC will accept circuits from the UK and Punta Arenas after processing through coherent kits on station. Goddard will provide analog facilities to the VAX 11/780 in Building 21, Room C-222 which will be connected to an RDS-provided Racal-Milgo 9632 modem. GSFC will also provide analog facilities from the switch to Building 21, Room C-222 for connection to a Ricoh 2100 facsimile. GSFC will provide analog telephone instruments to be used on both circuits in Building 21. The data from NOAA will most probably be carried by tape and put into a VAX at GSFC. The VAX will be equipped with DECNET software to communicate with a designated computer at ECMWF. The ability will exist for dialing the appropriate off-premise extension number of ECMWF directly and tell the ECMWF operator that they are ready to transmit data. ECMWF will make the necessary patch to remove that line from the PABX and place it on line with the Racal Milgo 9632 modem used for data (as previously discussed).

In addition to the four international lines, an INMARSAT circuit will be provided to interconnect Palmer Station with the Operations Center in Punta Arenas. This will be a voice only circuit. The International Gateway in Connecticut will be accessed via the CBX-9000 on FTS. All calls will be dial up and charged by the minute.

Operation of the System

With the above stated configuration, a person in the U.S. who requires communication with the RDS-NASA Communications Center in Punta Arenas will simply dial the 7-digit number on the CBX 9000 at GSFC and immediately ring the number in Punta Arenas either for the Nefax/telephone instrument or the telephone instrument associated with the u-VAX. If the line is in use, they will receive a busy signal as with any other call.

A project member with authorization from the appropriate person in-charge in Punta Arenas will pick up the telephone instrument and dial either a local number or the appropriate FTS number for the U.S. correspondent required. If fax is required, the person, upon hearing the fax tone, will start the machine.

A person in the U.S. requiring data transmission will dial the 7-digit number that will ring the instrument associated with the Racal-Milgo 9632 modem in the RDS-NASA Communications Center in Punta Arenas and commence communication. In Britain, a person requiring voice communication with Punta Arenas may call either of 2 numbers, one assigned to the ECMWF PABX from the Reading telephone exchange or the PABX at BMO with direct connection to the Bracknell telephone exchange. At either of these two sites, the PABX will provide direct connection to Punta Arenas.

A project person in Punta Arenas who requires communication with Britain will simply pick up either telephone that is available and dial 9 and receive the dial tone from either Reading or Bracknell telephone exchanges and proceed to dial the number.

A person in Punta Arenas requiring communication to the U.S. during a communication outage between Punta Arenas and the U.S. may pick up the telephone to the ECMWF, dial the extension of the line connected to GSFC and receive a dial tone directly from GSFC. By the same token, if there is an outage that occurs between the UK and Chile, the person in Punta Arenas at the RDS-NASA Communications Center will pick up the telephone and receive dial tone from GSFC. He/she will then dial the appropriate on-base extension number of ECMWF. If it is desired to transmit data, the operator will make the connection via the patch panel. If it is desired to access any other extension, they may be accessed directly. The ECMWF operator may patch directly to BMO, should this be desired, or should an emergency occur requiring a circuit to be rerouted in this manner.

RDS: Real-Time TOMS Support

The horizontal distribution of total column ozone amounts can be remotely sensed over the globe on a daily basis by the Total Ozone Mapping Spectrometer (TOMS) on board the Nimbus-7 satellite. The data from the TOMS instrument affords researchers a unique real time glimpse of the development of the Antarctic ozone hole.

One objective of Research and Data Systems (RDS) Corporation, in support of the experiment and under the direction of Dr. Arlin Krueger of NASA/GSFC, is to provide TOMS data at Punta Arenas, Chile to assist in directing flights of the NASA ER-2 and DC-8 aircraft into the Antarctic ozone hole.

The near real-time data will be used to direct the aircraft by providing the locations of the ozone hole boundary and navigational information for the mission. For the mission planning and operations, the ER-2 flights will require limited area coverage in real time from orbits ascending over South America. With their greater range, the DC-8 flights, and project planning activities in general, will require the TOMS data with full polar coverage daily.

RDS is setting up, operating, and maintaining the telecommunications necessary to deliver the real-time ozone data from the GSFC to Chile on a daily basis during the field experiment.

**OZONE HOLE EXPERIMENT
--TELECOMMUNICATIONS NETWORK**

RDS research and data systems, corp.
10000 GREENBELT ROAD LANHAM, MARYLAND 20706-2100 (301) 964-4000

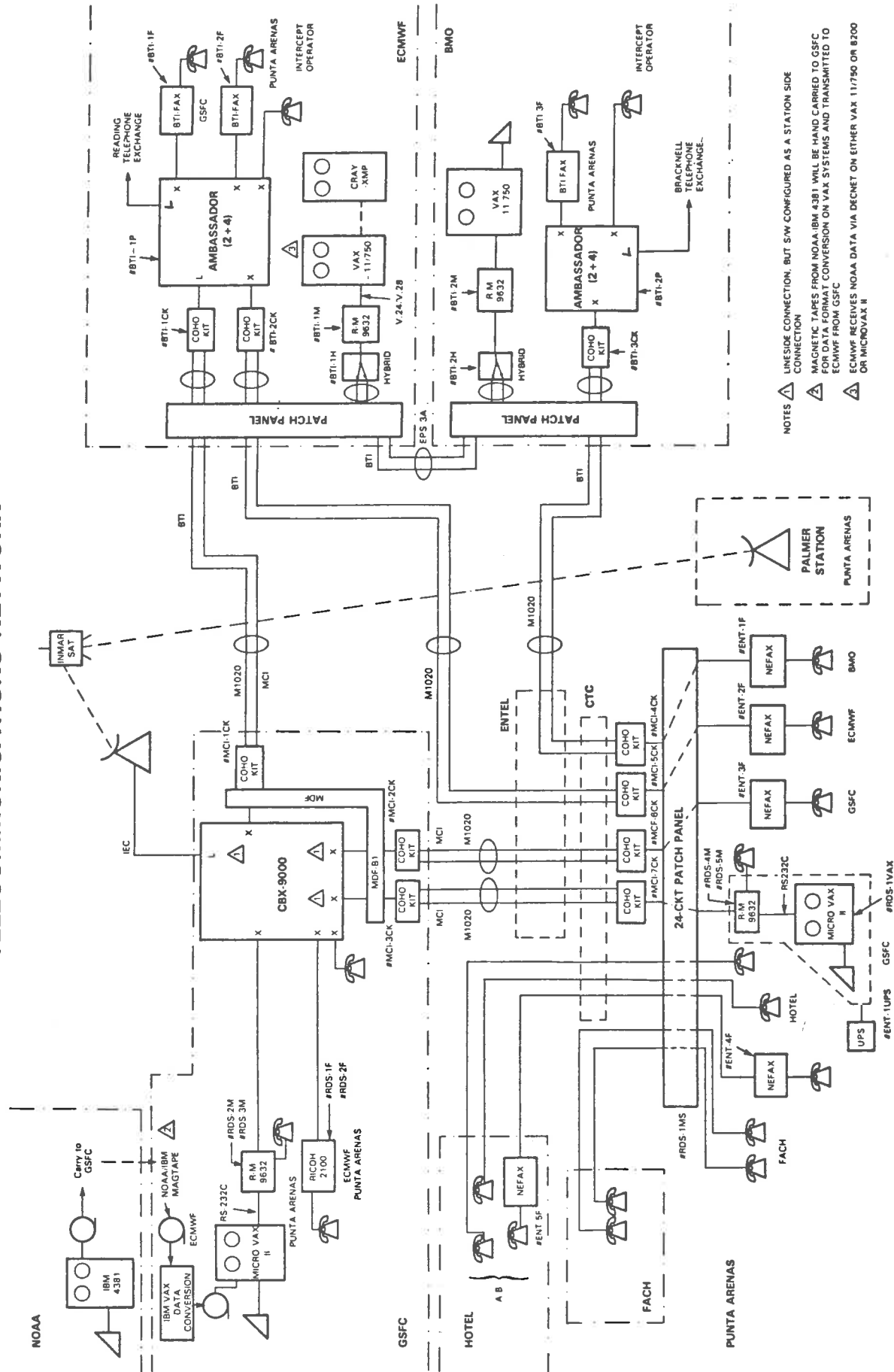

NOTES
 △ LINESIDE CONNECTION, BUT SW CONFIGURED AS A STATION SIDE CONNECTION
 △ MAGNETIC TAPES FROM NOAA (IBM 4381) WILL BE HAND CARRIED TO GSFC FOR DATA FORMAT CONVERSION ON VAX SYSTEMS AND TRANSMITTED TO ECMWF FROM GSFC
 △ ECMWF RECEIVES NOAA DATA VIA DECRET ON EITHER VAX 11/750 OR 8200 OR MICROVAX II

ANTARCTIC OZONE DATA PROTOCOL

INTRODUCTION

The following data protocol and publication guidelines have been prepared to encourage the orderly and efficient analysis, interpretation, and publication of the scientific results obtained during the project. It is hoped that the development and distribution of this plan will enhance the overall science output by encouraging the early publication of results and promoting cooperation among the investigators.

Antarctic Ozone Investigators

The Principal Investigators are listed in Table 1.

DATA PROTOCOL

Release and publication of data from the Antarctic Ozone Project are planned to occur with the following schedule:

1. At the conclusion of the mission in Punta Arenas, an "End of Mission Statement" will be drafted by the entire scientific team. This statement will serve as a Press Release and contain a summary of the preliminary scientific findings of the mission. It will only contain those observations (data and interpretations) that are clear and unambiguous, and unlikely to change upon further examination. This statement will serve to inform the public of what we have learned. It will not present data in a manner adequate for rigorous, scientific analysis by other scientists. Release of data to the scientific community is covered in Item 3 of this section. The End of Mission Statement will serve as the basis for discussions with the press, public, and policymakers during the proprietary period.
2. A data workshop will occur 4 months after the mission. Data in a reduced format useful to the other Investigators and to the workshop proceedings

will be due in a visual format (charts, graphs, tables, etc.) in the project office concurrent with this workshop.

3. The initial, major public release (publication) of the scientific data from the mission is planned for approximately 8 months after the end of the mission (e.g., May 1988), either in a special workshop/meeting and/or as a special journal issue. It is anticipated that major scientific conclusions, together with the data supporting those conclusions will be released at this time to the scientific community as part of the workshop proceedings or special journal issue.

A. Proprietary Period

Except for data released in the special workshop/publication (Item 3), the data of each investigator are proprietary for 12 months after the mission. By the end of this period, all reduced data will have been submitted to the Project Office Data Archive. This archive will be released to the scientific community at the end of the 12 month proprietary period.

Prior to the release of the archive, the following data protocol is in effect:

1. During the Antarctic Ozone missions, the Principal Investigators are responsible for making "quick-look" data available within 6 hours after flight completion for use in quality assessment and mission planning. The "quick look" data will consist of (a) plots on a scale of 10 inches per hour and (b) data for interchange on a 5¼ inch, 360 K low density double sided diskettes using MS-DOS.
2. Each Investigator is responsible for the evaluation of the performance of his or her instrument and for the initial analysis, interpretation, and publication of the data obtained by his or her instrument.
3. No unpublished data of another Investigator may be used in a publication or presentation without the participation or consent of that Investigator.

4. The Investigators may release their own data to whomever they wish. They may not release the data of other Investigators. Anyone who wants another investigator's data can **ONLY** get them from that investigator. Collaboration (dissemination of data) beyond the initial co-investigators should be documented to include the scope of the collaboration and agreement to this data protocol, with a copy of the document to be sent to the Project Scientist and Office. Any data made available to an outside collaborator must also be made available to the rest of the Science Team.
5. An Investigator whose unpublished data are to be used in a study has the right to be included among the authors of any resulting publication. The Investigator must provide information concerning the quality of the data and may require that suitable caveats regarding the data be included in the publication. It is the responsibility of the person initiating the study to solicit the participation of the Investigator whose data are to be used as early as possible during the formative stages of the study.
6. The title, description, and participants of a proposed study should be forwarded to the Project Scientist and the Project Manager during the formative stages of the study. The Project Scientist will inform all Science Team members of the status of the proposed and completed studies.
7. Data sets developed from collaborative studies using Antarctic Ozone data will be made available to the Data Archive. This includes all collaborative efforts both within and outside the Science Team membership.
8. During the proprietary period, studies utilizing unpublished Antarctic Ozone data must be sponsored by an Antarctic Ozone Investigator. Scientists who are not Project members, co-investigators or associates may participate in investigations using unpublished data provided they are sponsored by an Investigator, and they make available other data they plan to use to the data archive.

9. Lists of on-going studies will be compiled and kept current by the Project Office. Notice to participants of deadlines for workshops and journal issues will be the responsibility of the Project Office.

B. Post-proprietary period

Twelve months after the conclusion of the Antarctic missions, the data archive will be available to the scientific community. The scientist must provide information concerning the quality of his data in the archive and he may require that suitable caveats regarding the data be included in the publication of the archive.

Table 1 - Science Team

Adrian Tuck, Project Scientist
Brian Toon, Deputy Project Scientist

ER-2 Principal Investigators

Jim Anderson, Harvard Univ.	Ken Kelly, NOAA AL
K. Roland Chan, NASA Ames	Max Loewenstein, NASA Ames
David Fahey, NOAA AL	Verne Oberbeck, NASA Ames
Guy Ferry, NASA Ames	Michael Proffitt, NOAA AL/CIRES
Bruce Gandrud, NCAR	Walter Starr, NASA Ames
Bruce Gary, JPL	Jim Vedder, NASA Ames
Leroy Heidt, NCAR	J. Charles Wilson, U. of Denver

DC-8 Principal Investigators

Ed Browell, NASA Langley	Ken Kelly, NOAA AL
C. Barney Farmer, JPL	William Mankin, NCAR
Gerry Gregory, NASA Langley	Jim Vedder, NASA Ames
Leroy Heidt, NCAR	Andreas Wahner, NOAA AL

Satellite Principal Investigators

D. Cariolle, CNRM
A. Krueger, NASA Goddard
P. McCormick, NASA Langley

Theory Team

D. Hartmann, U. of Wash.
R. Jones, UK Met O
J. Rodriguez, AER, Inc.
M. Schoeberl, NASA Goddard
N. Sze, AER, Inc.

ANTARCTIC
OZONE

FIELD
OPERATION

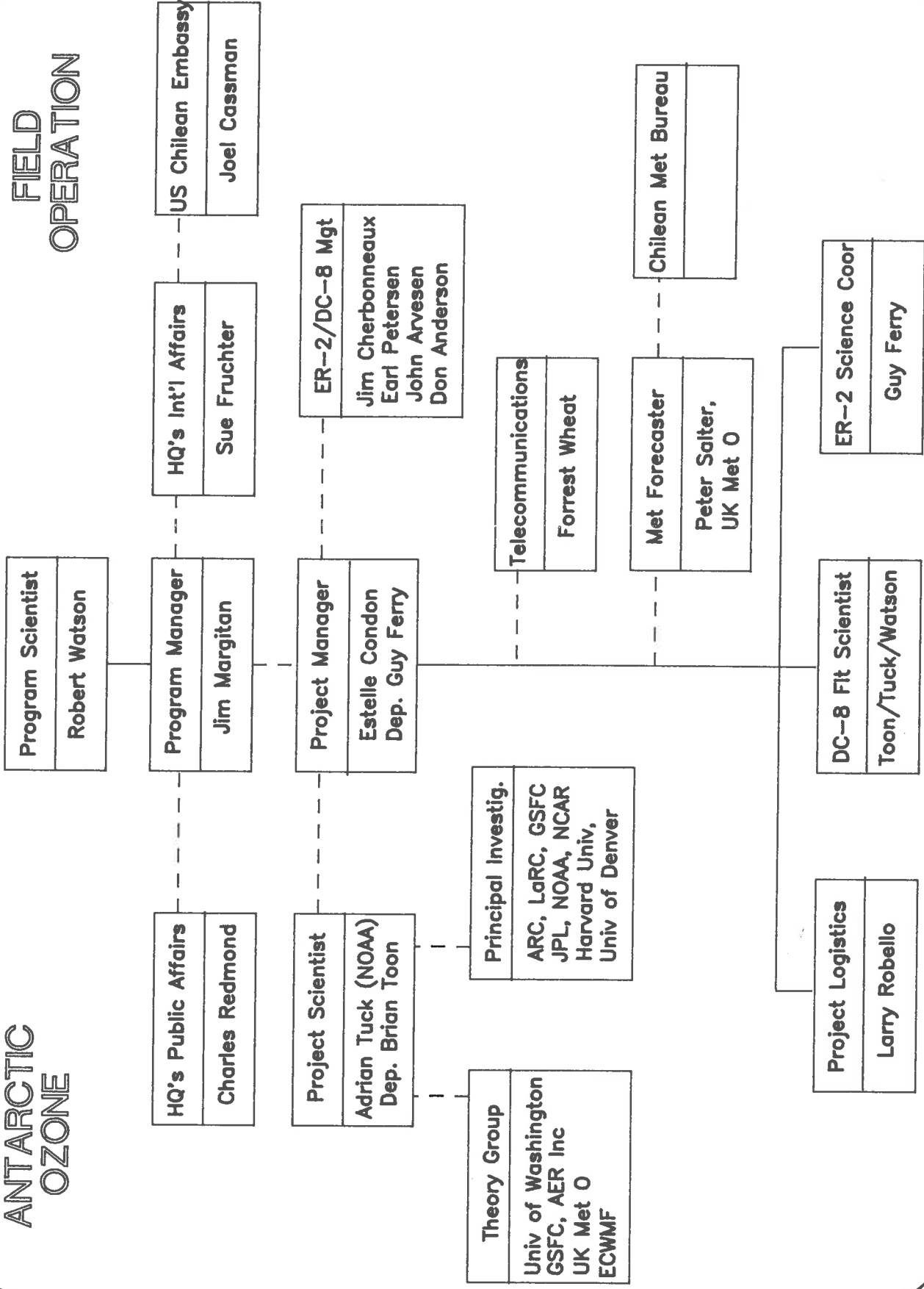

Appendices

FLight Track Maps

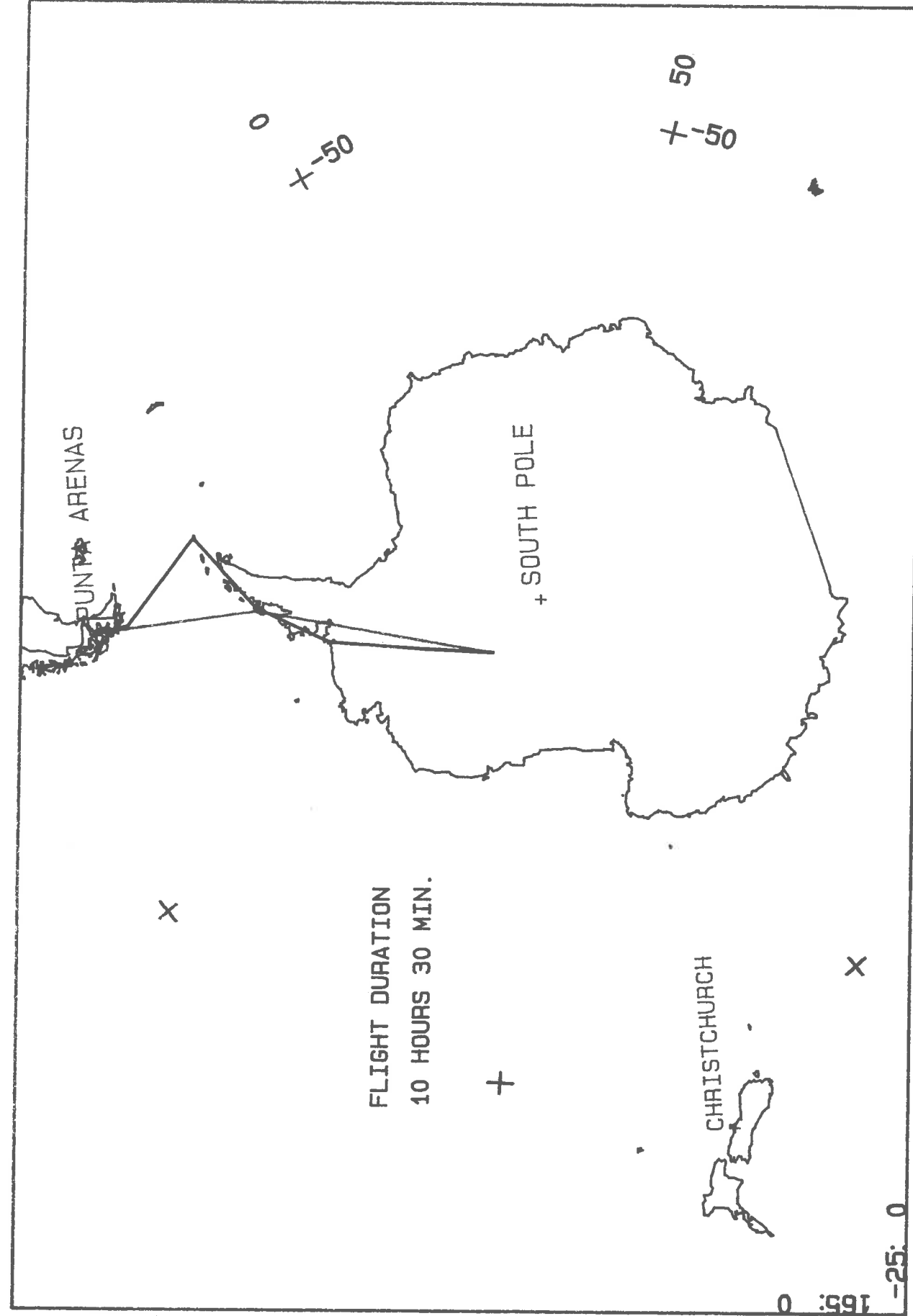

DC-8 ANTARCTIC OZONE EXP. PROPOSED FLIGHT PLAN #1
1: 24 PM WED., 1 JUL., 1987
DC8FLT-1.FLT
SCALE = 1:5.00E+07

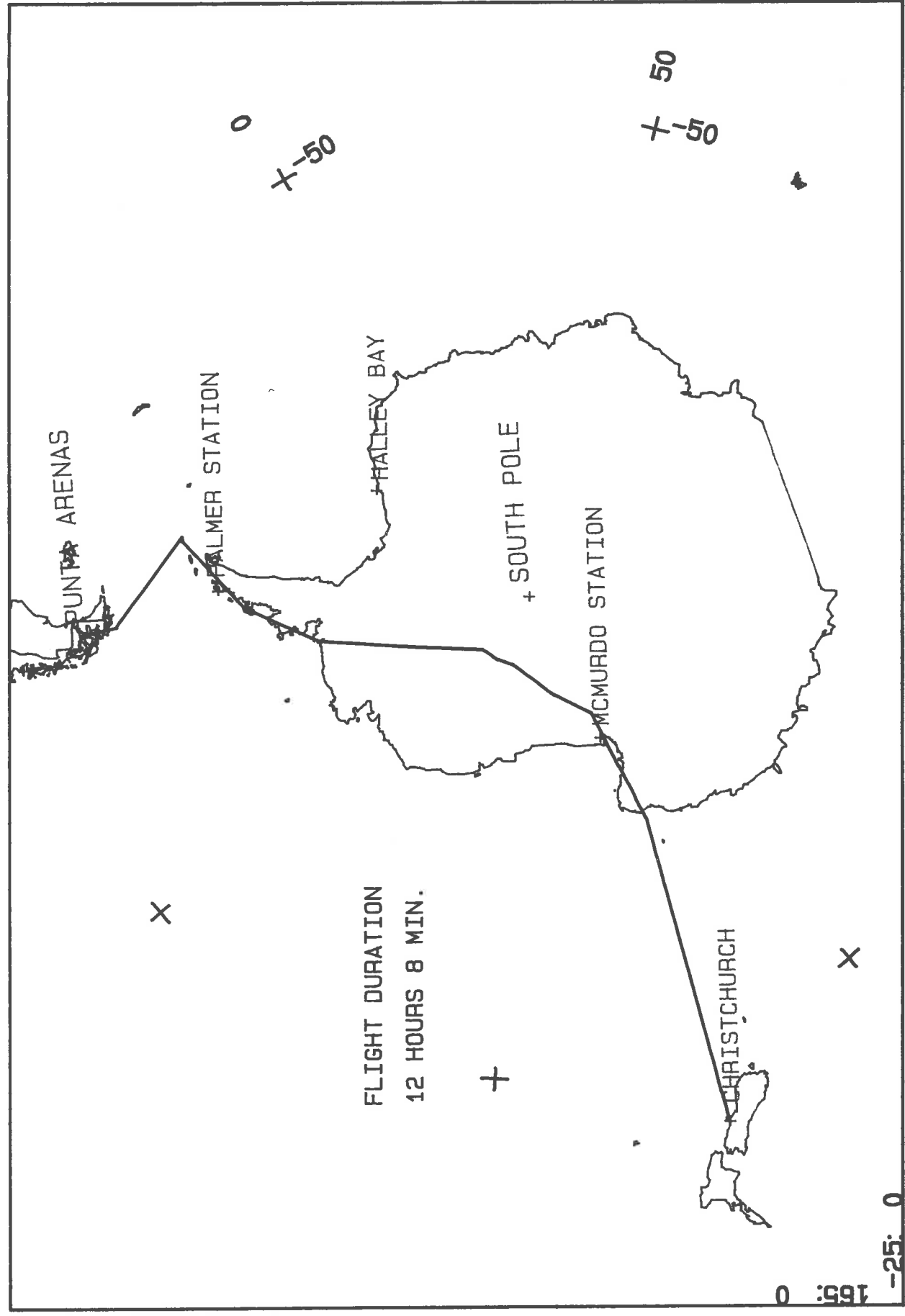
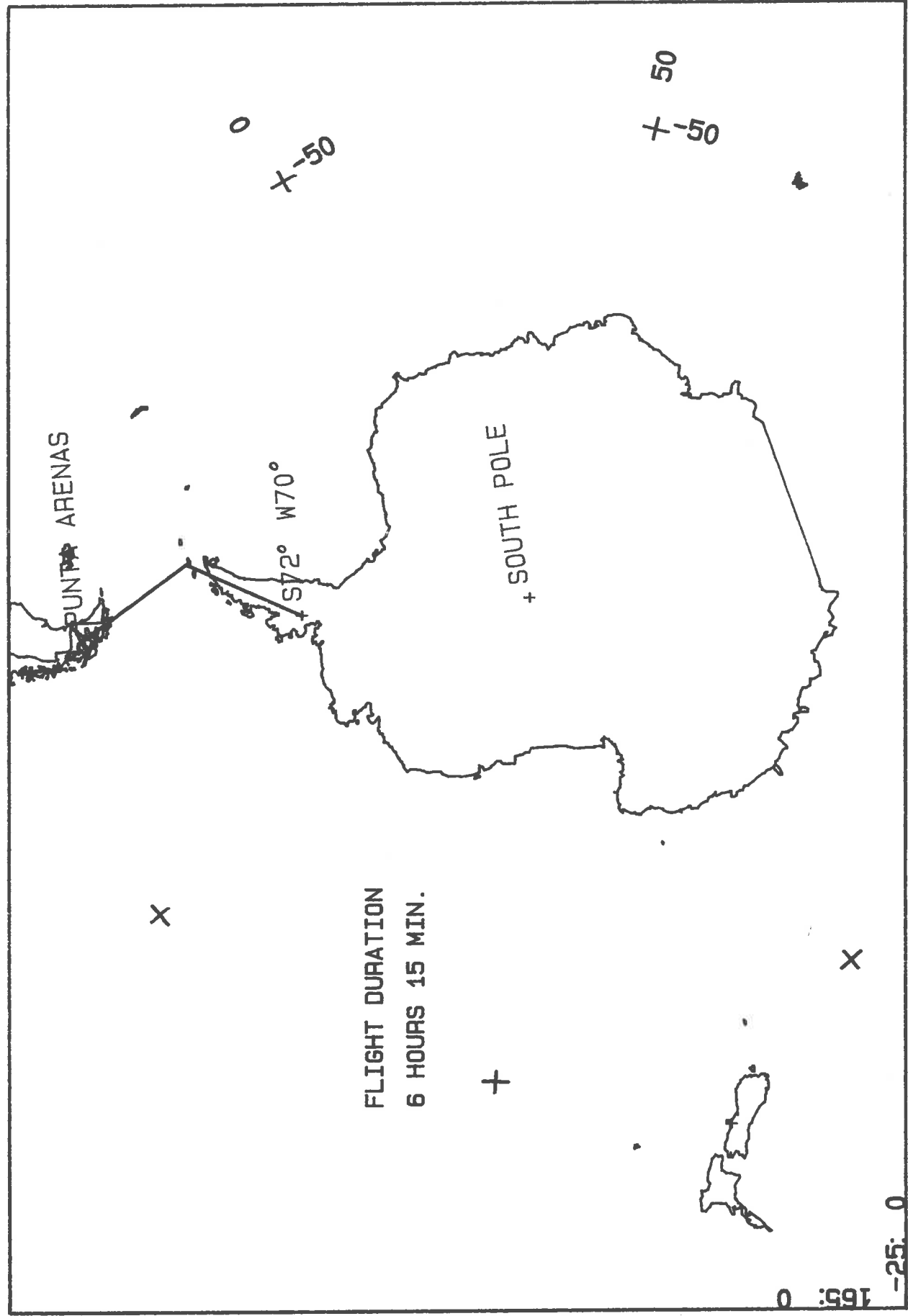

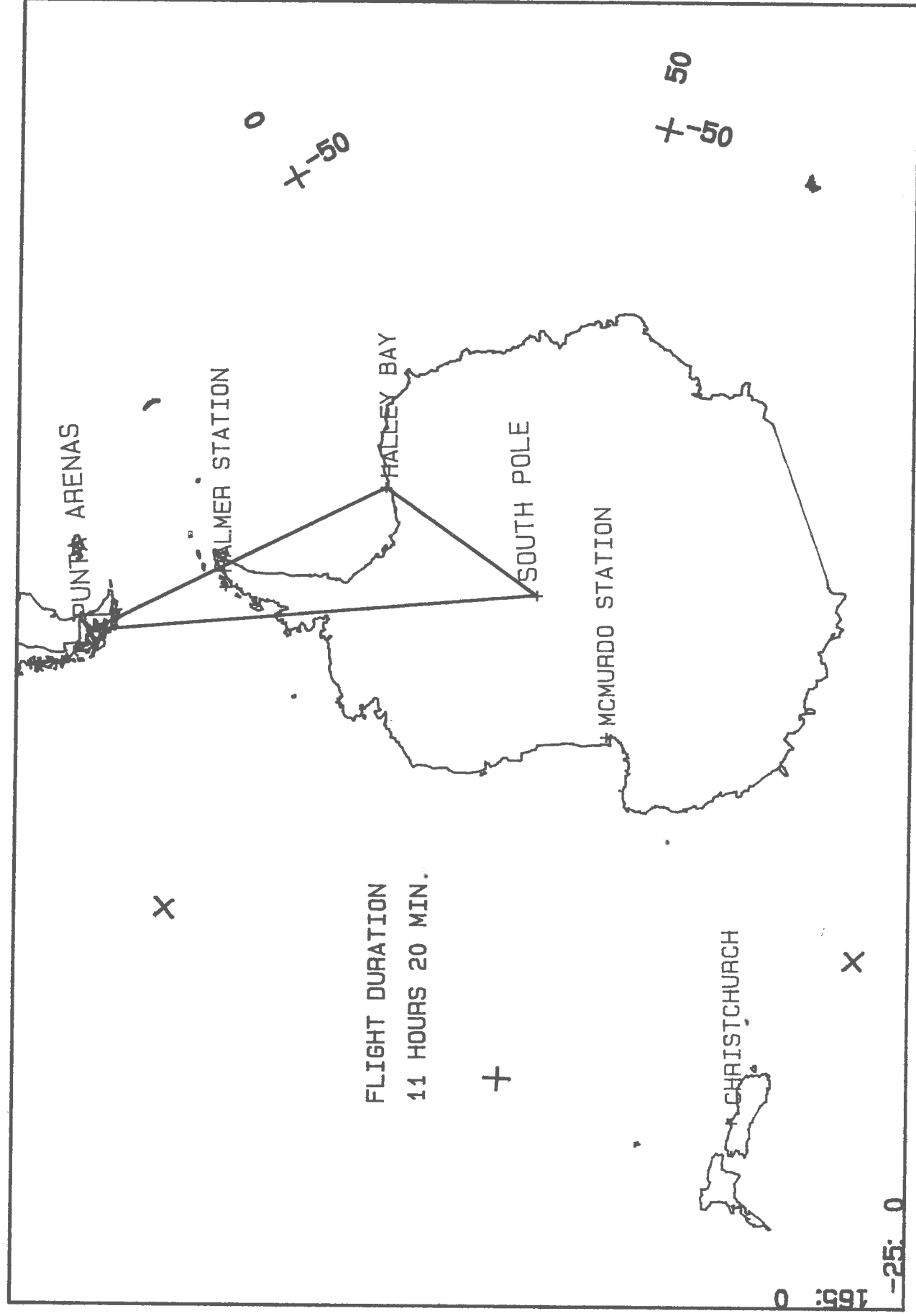

DC-8 ANTARCTIC OZONE EXP. PROPOSED FLIGHT PLAN #5
 1: 56 PM WED., 1 JUL., 1987
 DC8FLT-5.FLT
 SCALE = 1: 5.00E+07

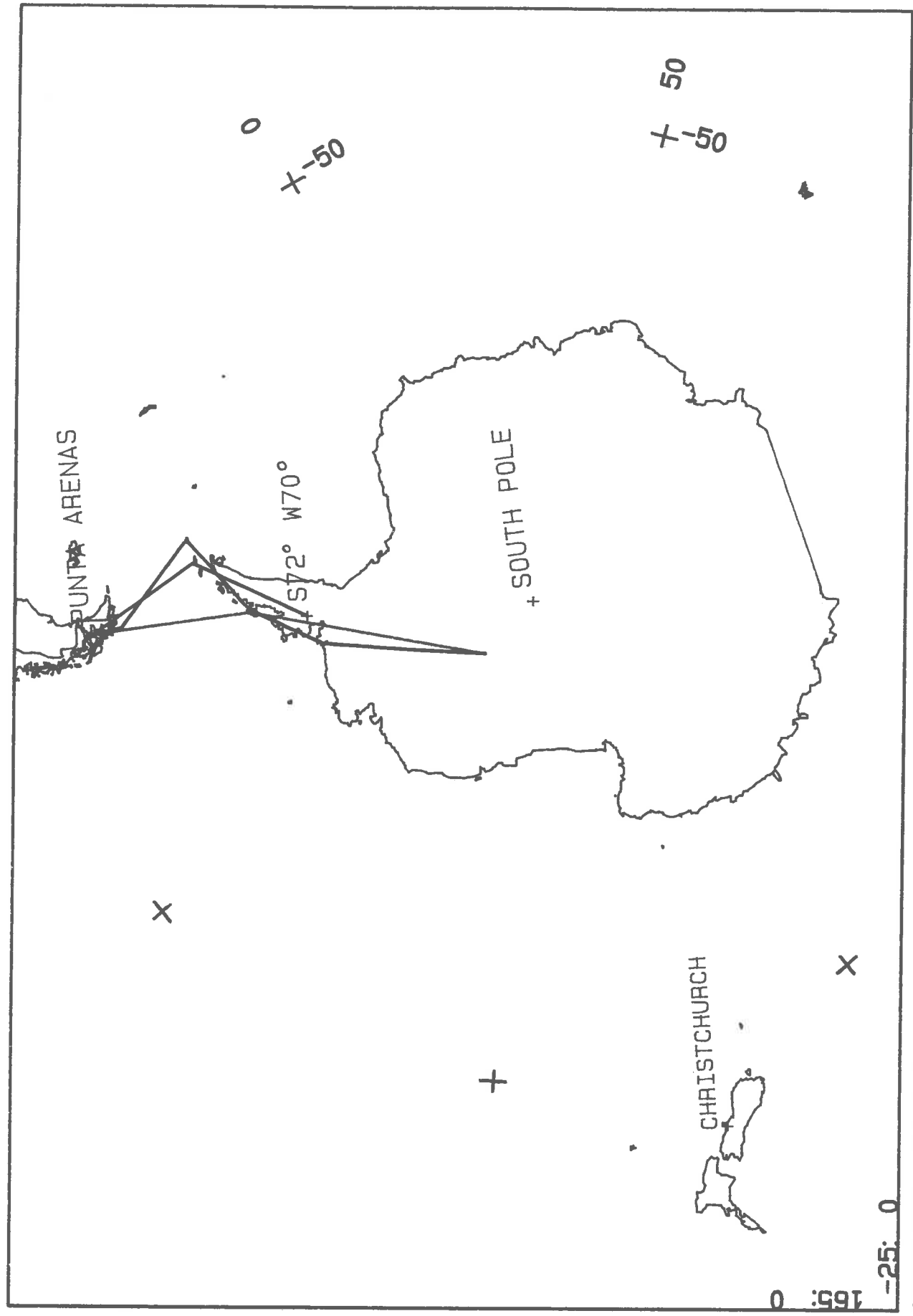

PROPOSED JOINT DC-8 AND ER-2 FLIGHT PLAN DC-8 = BLUE, ER-2 = RED
 12: 38 PM WED., 1 JUL., 1987
 DC8FLT-1.FLT
 SCALE = 1: 5.00E+07

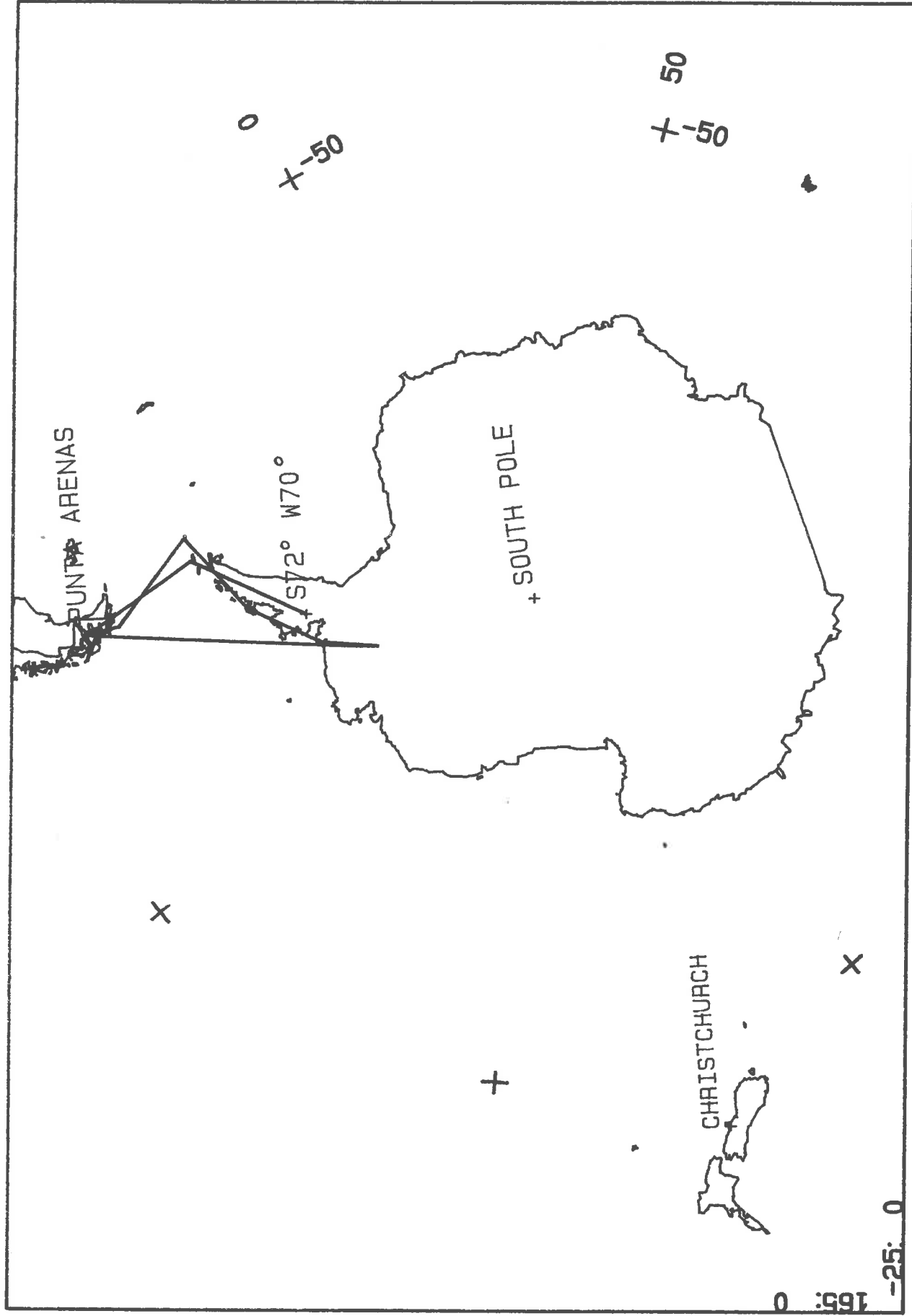

-25: 0

PROPOSED JOINT DC-8 AND ER-2 FLIGHT PLAN DC-8 - BLUE, ER-2 - RED
 12: 45 PM WED.. 1 JUL.. 1987
 DC8FLT-4.FLT

SCALE = 1:5.00E+07

Schedule

??
?
? OZONE DEPLETION MISSION SCHEDULE ?
? AIRCRAFT ER-2 (NASA 706) ?
?
?
?
?
??

- A. AIRCRAFT
M aircraft maintenance
E equipment installation
B. EXPERIMENTS
d experiment design
D experiment interface design
F experiment interface fabrication
I experiment interface installation
C. FLIGHTS
P pilot training/proficiency
f ferry flights
+ data flights
T experiment checkout
D. MISCELLANEOUS
* meeting dates
^ event date
E. RESPONSIBILITY
1 OM
2 OMH
3 OA
4 SSG
5 NASA HQ
6 PROJECT SCIENTIST

RESPONSIBLE MAR APR MAY JUNE JULY AUG SEPT OCT

Table with columns for RESPONSIBLE, MAR, APR, MAY, JUNE, JULY, AUG, SEPT, OCT. Rows include: I. ER-2 MAINTENANCE/DPS, II. OZONE HOLE DEPLOYMENT, III. AVIONICS EQUIPMENT, IV. OZONE EXPERIMENTS, V. FLIGHT & AIRWORTHINESS OPERATIONAL READINESS.

??
?
? OZONE DEPLETION MISSION SCHEDULE ?
? AIRCRAFT ER-2 (NASA 706) ?
?
?
?
?
??

- A. AIRCRAFT
M aircraft maintenance
E equipment installation
B. EXPERIMENTS
d experiment design
D experiment interface design
F experiment interface fabrication
I experiment interface installation
C. FLIGHTS
P pilot training/proficiency
f ferry flights
+ data flights
T experiment checkout
D. MISCELLANEOUS
* meeting dates
^ event date
E. RESPONSIBILITY
1 OM
2 OMH
3 OA
4 SSG
5 NASA HQ
6 PROJECT SCIENTIST

RESPONSIBLE MAR APR MAY JUNE JULY AUG SEPT OCT

Table with columns for RESPONSIBLE, MAR, APR, MAY, JUNE, JULY, AUG, SEPT, OCT. Rows include: VI. FACILITIES SUPPORT, VII. TRAINING, VIII. POLITICAL ARRANGEMENTS.

03/18/87

??
 ? OZONE DEPLETION MISSION SCHEDULE ?
 ? AIRCRAFT DC-8 (NASA 717) ?
 ? ? ?
 ???

- A. AIRCRAFT
 - M aircraft modifications
 - E equipment installation
- B. EXPERIMENTS
 - d experiment design
 - D experiment interface design
 - F experiment interface fabrication
 - I experiment interface installation
- C. FLIGHTS
 - P pilot training/proficiency
 - f ferry flights
 - + data flights
 - T experiment checkout
- D. MISCELLANEOUS
 - * meeting dates
 - ^ event date
- E. RESPONSIBILITY
 - 1 OM
 - 2 OMM
 - 3 OA
 - 4 SSG
 - 5 NASA HQ
 - 6 PROJECT SCIENTIST

RESPONSIBLE JAN-MAR APR MAY JUNE JULY AUG SEPT OCT

RESPONSIBLE	JAN-MAR	APR	MAY	JUNE	JULY	AUG	SEPT	OCT
I. DC-8 MODIFICATIONS/INSTALLATION								
A. AIRCRAFT PHASE I MODIFICATIONS (WACO, TX)	2 (ANDERSON/RELLER)	MMMMM	MMMMM	MM[21]				
B. DELIVERY TO ARC & PILOT PROFICIENCY				[22]fpp	[29]			
C. NSI MODS & EQUIPMENT INSTALLATION				EEEEEE	E[6]			
D. STERLING DATA ACQUISITION MODS				EEEEEE	E[6]			
II. OZONE HOLE EXPERIMENT	2 (RELLER)							
A. EXPERIMENT INTEGRATION					IIIII	[30]		
B. TEST FLIGHTS						T[7,9]		
C. FERRY TO POINT ARENAS, CHILE					[11]ff	[14]		
D. DATA FLIGHTS					[17]+++++	+++++[27]		
E. RETURN TO ARC							[29ff]	[30]
III. AVIONICS EQUIPMENT	3 (ANDERSON)							
A. APU		---	---	MMMMM				
B. INERTIAL NAVIGATION SYSTEM		---	---	MMMMM				
C. ENGINE MODIFICATIONS		---	---	MM				
IV. OZONE EXPERIMENTS	2 (PETERSEN)	[25,26]						
** OZONE EXPERIMENTERS MEETING @ ARC **		*						
A. LIDAR (BROWELL)			DDDDDD	DDDDFF	FFFFFF	FIIIIII		
B. OZONE (GREGORY)			DDDDDD	DDDDFF	FFFFFF	FIIIIII		
C. FTIR (MANKIN)			DDDDDD	DDDDFF	FFFFFF	FIIIIII		
D. DCLD (SCHMELTEKOPF)			DDDDDD	DDDDFF	FFFFFF	FIIIIII		
E. FTIR (FARMER)			DDDDDD	DDDDFF	FFFFFF	FIIIIII		
F. H20 - TOTAL (KELLY)			DDDDDD	DDDDFF	FFFFFF	FIIIIII		
G. AIR SAMPLER (HEIDT/VEDDER)			DDDDDD	DDDDFF	FFFFFF	FIIIIII		
V. FLIGHT & AIRWORTHINESS OPERATIONAL READINESS								
A. HAZARD ANALYSIS REPORT	1		---	---	^			
B. INTERNAL READINESS REVIEW	2/3				^			
C. AFSRP-M READINESS MTG (ACFT/EXPMTS)	2/3							[3]

03/18/87

??
 ? OZONE DEPLETION MISSION SCHEDULE ?
 ? AIRCRAFT DC-8 (NASA 717) ?
 ? ? ?
 ???

- A. AIRCRAFT
 - M aircraft modifications
 - E equipment installation
- B. EXPERIMENTS
 - d experiment design
 - D experiment interface design
 - F experiment interface fabrication
 - I experiment interface installation
- C. FLIGHTS
 - P pilot training/proficiency
 - f ferry flights
 - + data flights
 - T experiment checkout
- D. MISCELLANEOUS
 - * meeting dates
 - ^ event date
- E. RESPONSIBILITY
 - 1 OM
 - 2 OMM
 - 3 OA
 - 4 SSG
 - 5 NASA HQ
 - 6 PROJECT SCIENTIST

RESPONSIBLE JAN-MAR APR MAY JUNE JULY AUG SEPT OCT

RESPONSIBLE	JAN-MAR	APR	MAY	JUNE	JULY	AUG	SEPT	OCT
VI. FACILITIES SUPPORT								
A. SURFACE/AIR FREIGHT SHIPPING	2/4			S	AI	ARRIVE		
B. LAB FACILITY - DC-8 PIs	-	###	NONE AVAILABLE	###				
C. PI COMMAND POST	6							
D. MET. DATA (PT ARENAS, ANTARCTIC)	6							
E. TOMS SATELLITE DATA (OZONE POSITION)	6							
F. COMMUNICATIONS (TELEPHONE, TELEMAIL) FOR ITEMS C, D, & E	4							
G. DEMONSTRATION OF OPERATIONAL READINESS FOR ITEMS B, C, D, E, & F	2/4							[7]
VII. TRAINING								
A. PILOT PROFICIENCY	3			PP	[29]			
B. AUGMENTED FLIGHT CREW TRAINING	3							
C. DC-8 EGRESS (ALL FLIGHT PARTICIPANTS)	2							
D. AIRCRAFT FIRE TRAINING	2							
E. ARCTIC SURVIVAL TRAINING	1		^					
VIII. POLITICAL ARRANGEMENTS								
A. CHILE M.O.U.	2/5							
B. ARGENTINA M.O.U.	2/5							
C. OVER-FLIGHT CLEARANCES	2/5							

Master Mailing & Phone List

Met 015, Meteor. Office
London Office
Bracknell Berkshire
RG12 2SZ
GREAT BRITAIN
44-344-420242

Dr. Rod Jones
Dr. Peter Salter

NASA Headquarters
Code EEU
Washington, D.C. 20546
FTS 453-1681

Dr. M. Kurylo
Dr. J. Margitan
Dr. R. Watson

NASA Ames Research Center
Moffett Field, CA 94035
(415) 694- or FTS 464

245-5/R. Chan (x6263)
/E. Condon (x6071)
/G. Ferry (x5492)
/R. Guzman (x5489)
/R. Kolyer (x5503)
/M. Loewenstein (x5504)
/V. Oberbeck (x5496)
/J. Podolske (x5504)
/R. Pueschel (x5254)
/P. Russell (x5404)
/S. Scott (x5490)
/W. Starr (x5503)
/J. Vedder (x6259)

245-3/E. Danielsen (x5527)
/O. Toon (x5971)

240-6/J. Arvesen (x5376)
/J. Barrilleaux (x6360)
/G. Shelton (x5344)
/R. William (x5904)

240-2/J. Cherbonneau (x6102)
/E. Petersen (x6092)

211-12/D. Anderson (x5338)
/G. Grant (x5525)
/J. Reller (x5392)

200-7/P. Dyal (x6545)

NASA Goddard Space Flt Ctr
Greenbelt, MD 20771
FTS 344-6358

Dr. Arlin Krueger
Dr. Mark Schoeberl

Antarctic Ozone Mailing/Phone List
July 8, 1987

NASA Langley Research Center
Hampton, VA 23665-5225
FTS 928-

Dr. Ed Browell (x2576)
Mailstop 401A
Dr. G.L. Gregory (x4341)
Mailstop 483
Dr. Pat McCormick (x2065)
Mailstop 475

NCAR
P.O. Box 3000
Boulder, CO 80307
(303) 497-

Dr. Bruce Gandrud (x1425)
Dr. Leroy Heidt (x1459)
Dr. Bill Mankin (x1403)
Dr. Mike Coffey (x1407)

NOAA Aeronomy Laboratory
325 Broadway
Boulder, CO 80303
FTS 320-

Dr. Dan Albritton (x5785)
Dr. David Fahey (x5277)
Mr. Ken Kelly (x3355)
Dr. Michael Proffitt (x3345)
Dr. Art Schmeltekopf (x5340)
Dr. Adrian Tuck (x5485)
Dr. Andreas Wahner (x5826)

Jet Propulsion Laboratory
4800 Oak Grove Drive
Pasadena, CA 91109
FTS 792-

Dr. Bruce Gary (x3198)
Mailstop T1182
Dr. C.B. Farmer (x2039)
Mailstop 183-401

AER Inc.
840 Memorial Drive
Cambridge, MA 02139
(617) 547-6207

Dr. Jose Rodriguez
Dr. Nien Dak Sze

Dr. J. G. Anderson
Harvard University
40 Oxford Street
Cambridge, MA 02138
(617) 495-5922

Dr. D. Cariolle
CNRM
42 Avenue Coriolis
31057 Toulouse Cedex
FRANCE
33-61079381

Mr. William Ferguson
Lockheed California Company
P.O. Box 250
Sunland, CA 91040
(818) 847-2670

Dr. Dennis Hartmann
Dept. of Atmos. Science AK-40
University of Washington
Seattle, WA 98195
(206) 543-7460

Dr. R. Turco
R & D Associates
P.O. Box 9695
4640 Admiralty Way
Marina Del Ray, CA 90295
(213) 822-5922

Mr. Forrest C. Wheat
Research & Data Systems Corp.
10300 Greenbelt Road
Lanham, MD 20706
(301) 464-4402

Dr. C. Wilson
Dept. of Engineering
University of Denver
2390 South York, Room 216
Denver, CO 80208
(303) 871-3002

Information Copies

200-2/D. Compton (x5222)
200-7/A. Chambers (x5094)
245-1/L. Colin (x5028)
240-1/M. Knutson (x5358)

Antarctic Ozone Aircraft and Payloads

